

AQUA~FLOPAC™

INSTALLATION, OPERATION & MAINTENANCE FOR DUPLEX CONSTANT SPEED SYSTEMS

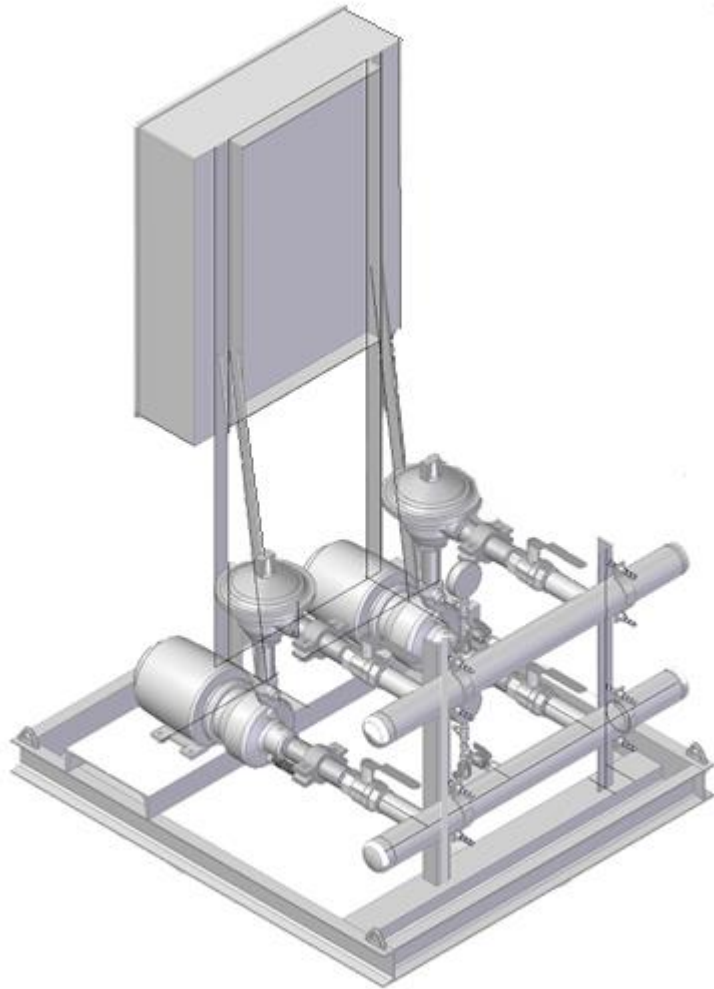

FLO-PAK®

A BUSINESS UNIT OF PATTERSON PUMP COMPANY

PO Box 790 . 9201 Ayersville Road

Toccoa, Georgia 30577

Phone: 706-886-2101

www.pattersonpumps.com

TABLE OF CONTENTS

SECTION 1

MECHANICAL & ELECTRICAL DATA

- Installation and Storage Requirements
- System Installation, Operation & Maintenance Manual
- Maintenance Schedule for Packaged Pump Systems
- Sequence of Operation
- Electrical Schematics
- Duplex Amperage Chart

SECTION 2

PUMPS

- Assembly Section for DAP 1 series, B05-83429
- Assembly Section for DAP 2 series, B05-82811
- Assembly Section for DAP 3 series, A05-83474
- Assembly Section for DAP 4 series, B05-83431
- Material List for HES Pumps

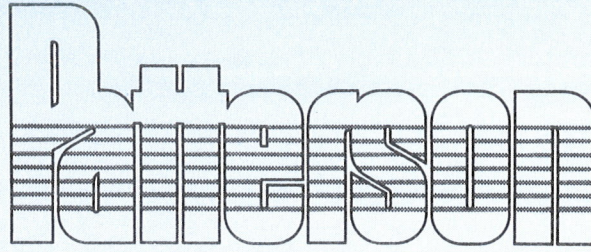

Warranty

Patterson Pump Company and Divisions of Patterson Pump Company ("Patterson") warrants, to the extent hereinafter set forth, each new piece of Patterson equipment to be free from defects in material and workmanship under the normal use and service for which it was intended if, and only if, it has been properly installed and operated.

Patterson's obligation under the warranty is limited to replacing or repairing, free of charge, F.O.B. point of manufacture, any defective part or parts of the equipment that were manufactured by Patterson and which are returned to Patterson at Toccoa, Georgia, provided that such part or parts are received at the Patterson factory not later than twelve (12) months after installation or eighteen (18) months after shipment whichever occurs first.

As to a part or parts such as engines, motors and accessories which are furnished by Patterson, but not manufactured by it, same will carry only the warranty of the manufacturer of such part or parts, and this shall be the limit of Patterson's liability with respect to such part or parts. Mechanical seals provided on commercial products (HVAC & Plumbing) are not covered by this warranty.

Purchaser must notify Patterson by registered or certified mail, return receipt requested, of a claimed breach of warranty within thirty (30) days after discovery thereof, but not later than the termination of the guarantee period hereinabove provided; otherwise, such claim shall be deemed waived.

Purchaser assumes all risk and liability whatsoever resulting from the use thereof, whether used singly or in combination with other equipment or machinery.

This warranty shall not apply to any Patterson Equipment, or parts thereof, which have been repaired or altered without Patterson's written consent, outside Patterson's factory, or which have been altered in any way so as in the judgement of Patterson, to affect adversely the performance or reliability of the Patterson equipment, or which have been subject to misuse, negligence or accident, or which have been operated under conditions more severe than, or otherwise exceeding, those set forth in the specifications for such equipment.

THIS WARRANTY IS FURNISHED EXPRESSLY IN LIEU OF ALL OTHER WARRANTIES, EXPRESS OR IMPLIED, INCLUDING ANY IMPLIED WARRANTY OF MERCHANTABILITY OR FITNESS FOR A PARTICULAR PURPOSE NOT OTHERWISE SET FORTH IN A WRITING SIGNED BY AN AUTHORIZED REPRESENTATIVE OF PATTERSON.

Patterson shall not be liable for any loss or damage resulting, directly or indirectly, from the use or loss of use of the equipment. Without limiting the generality of the foregoing, this exclusion from liability embraces the Purchaser's expenses for downtime or for making up downtime, and/or damage for which the purchaser may be liable to other persons, and/or damages to property, and/or injury to or death of any persons. Patterson neither assumes nor authorizes any person to assume for it any other liability in connection with the sale or use of the Patterson Equipment.

PATTERSON PUMP COMPANY / A Gorman-Rupp Company
2129 Ayersville Road
Box 790 / Toccoa, Georgia 30577 (706) 886-2101 / FAX (706) 886-0023
www.pattersonpumps.com

INSTALLATION AND STORAGE REQUIREMENTS FOR PUMP SKID UNIT

INSTALLATION:

1. The skid mounting surface can be a pad, but preferably a footing to support the entire perimeter of each of the skid unit(s). This footing should be designed in accordance with local building codes for the support of similar steel structures.
2. Typically the skid will be fabricated **WITHOUT** anchor bolt holes. Anchoring of the skid is done by placing anchor bolt plates over the bottom of the skid framing member and securing to the footing with expansion or epoxy anchor bolts. The skid is leveled, piping and electrical installation are complete before anchoring. For most installations, a total of eight (8) such anchors are recommended (local authorities may dictate otherwise) for each unit. This would include two (2) anchors down each long side (evenly spaced), with one (2) at each end (evenly spaced). For suggested anchor detail, see sketch attached.
3. After the skid is installed and leveled, but before anchoring, check the doors for fit and ease of movement. The entire package is assembled on a level surface at the factory and checked for proper operation before shipment. Occasionally, when the building is set, the doors do not line-up as they should. This can usually be corrected by shimming to level the skid on the foundation. Some experimenting may be required as each footing will vary slightly and the shim may need to be shifted until satisfactory door alignment is achieved. Once proper alignment is achieved the skid should be anchored down and the interior of the skid filled with concrete over a packed granular fill (gravel). The concrete should be 4"-6" thick and finished with some surface texture. For deckplated skids, the perimeter members of the skid should be grouted.
4. For skids with poured concrete floors, once the floor has cured the baseplate is to be grouted with a non-shrink grout.
5. The field electrician will need to connect the building heater. The field electrician is responsible for grounding the building per local codes.
6. All bolts need to be tightened after shipment. Bolts can become loose due to vibration from traveling and loading and unloading.
7. All valves are to be in the closed position prior to filling the system.
8. All drains in system that are to be field connected need to be routed appropriately by the installing contractor.
9. It is the installing contractor's responsibility to inspect the entire package before receiving the unit. Any damage must be noted in writing on the bill of lading. Pictures should be taken when possible. Failure to do so could result in a denial of a warranty claim.
10. All flexible coupled pumps shall be field aligned once the building has been anchored. Pumps are factory aligned, but vibrations in shipping and flexing of the station during loading and unloading may change the alignment. This shall be done by the installing contractor.

STORAGE:

1. Place on a dry, hard, level surface.
2. Protect from weather and airborne contamination (if not enclosed).
3. Protect from effects of temperature extremes and humidity, to prevent condensation.
4. Protect from physical damage.
5. Maintain corrosion protection on exposed bare metal surfaces.
6. Rotate pump shaft by hand at least once per week. Rotate two revolutions stopping at a point 90 degrees from the initial shaft position.

SKID UNLOADING GUIDE

LIFT ARM POSITIONING:

- The skid lifting arms consist of two pipes inserted through two larger Sch 40 pipes that are an integral part of the skid structure. The smaller pipes are approximately 4 FT longer than the skid width and when properly positioned will expand beyond the skid on each side. It is recommended that the lifter cables not be located farther than 6" from the skid structure.
- On larger units, the lifting arms are welded in place and are approximately 8 inches wider than the skid width, 4 inches on each side.
- On small units, four 5/8" eyebolts are used instead of lifting arms.

RIGGING:

- The lower cables attach between the four lift points on the skid and the spreader bar (see sketch). The cables (supplied by the crane operator) should be long enough so that the angle between the cables does not exceed the recommendation of the cable supplier. We have found that an included angle of 40-45 degrees between cables allows for good stability. The longer the cables, the more stable the load.
- The spreader bar (supplied by the crane operator), should be about two feet wider than the skid base. The upper cables should be somewhat longer than the lower cables (approximately 20%). Again, the cable manufacturer's recommendation should be followed.
- Proper rigging of the skid for lifting is the responsibility of the customer. The above rigging suggestions are meant only as a guide and are not to be construed as complete instructions, consequently Patterson Pump Company shall not be responsible for the use or misuse of these suggestions. The customer is encouraged to retain the services of a qualified contractor experienced in the rigging of similar structures.

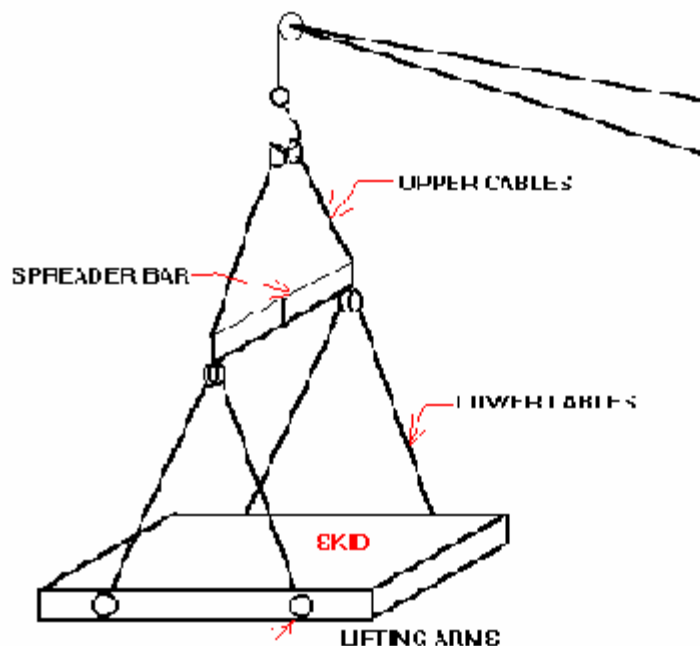

CONFIDENTIAL PROPRIETARY NOTICE
THE INFORMATION INCLUDED HEREIN
IS OWNED BY FLO -PAK.
THIS INFORMATION IS PRESENTED SOLELY
TO AID IN THE APPLICATION OF
FLO-PAK PRODUCTS AND MAY NOT BE
USED FOR ANY OTHER PURPOSE WITH-
OUT SPECIFIC WRITTEN PERMISSION FROM
FLO-PAK.
FURNISHING OF THIS INFORMATION
DOES NOT CONSTITUTE
AUTHORIZATION OR LICENSING FOR
ANY OTHER USE.
PIPE SUPPORTS NOT
SHOWN FOR CLARITY.

THIS DRAWING IS
CERTIFIED
 FOR APPROVAL
NO PRODUCTION WILL START
UNTIL APPROVED IN WRITING
 FOR CONSTRUCTION
PRODUCTION HAS STARTED
AND THIS DRAWING WILL AFFECT
PRICE AND DELIVERY
OUR ORDER NO. NONE
CUST. ORDER NO. _____
BY: _____ DATE 02/02/00

KEY LEGEND
KEY DESCRIPTION

PROJ. CODE:	---
CHECKED BY:	---
DRAWN BY:	J.P.
DATE:	02/02/00
SCALE:	NONE
DWG. NO.:	---
REV. DATE:	---
DESCRIPTION:	---

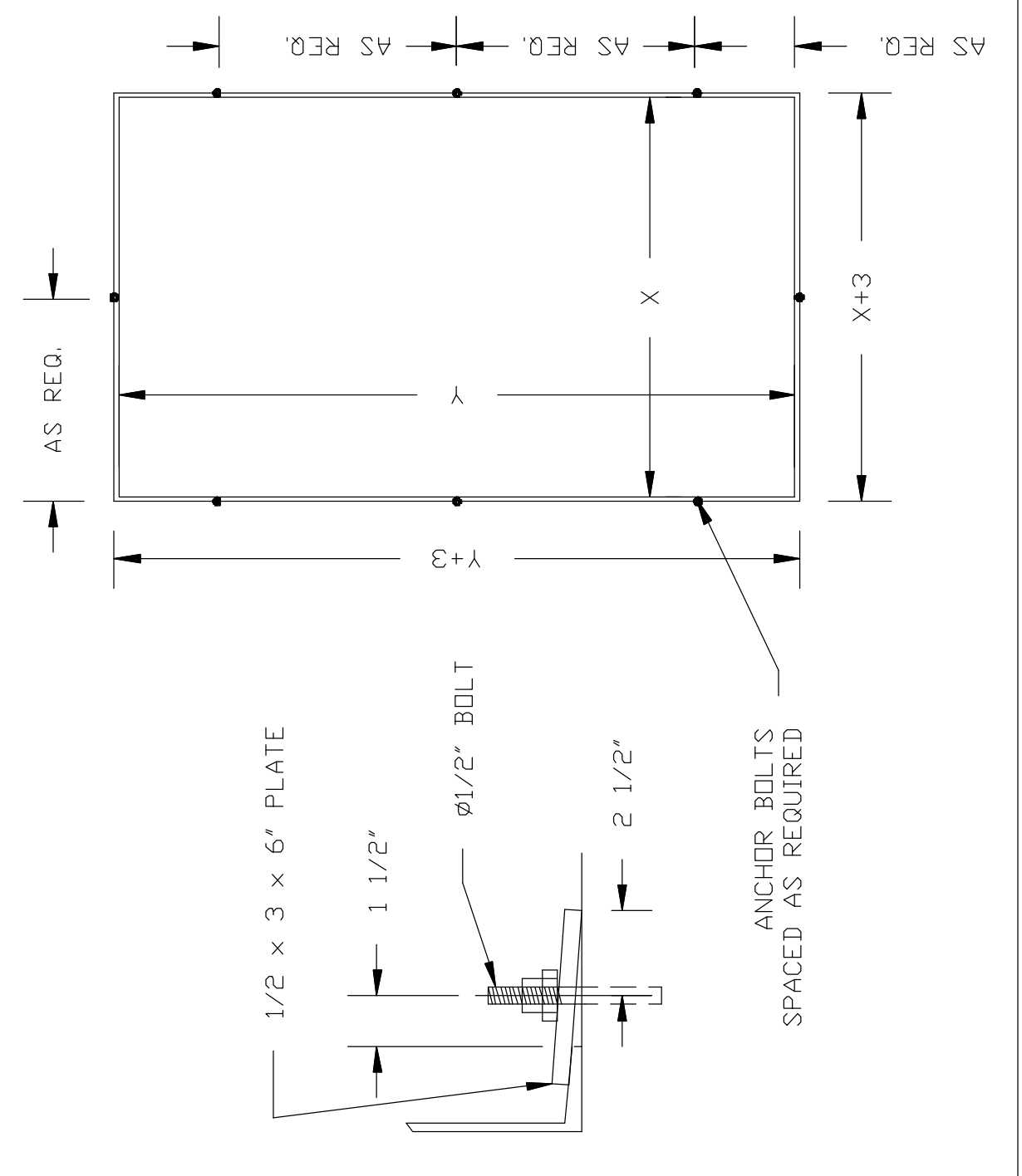

CERTIFIED FOR APPROVAL ONLY X
CERTIFIED FOR CONSTRUCTION



A BUSINESS UNIT OF PATTERSON PUMP COMPANY

P.O. BOX 790

Toccoa, Georgia 30577

Telephone: 706-886-2101

Fax: 706-886-0023

www.flo-pak.com

INSTALLATION, OPERATION & MAINTENANCE MANUAL

Read this entire manual before proceeding.

SECTION I – INTRODUCTION

- 1-1** This manual provides general instructions for the installation and maintenance of the package pumping unit manufactured by Flo-Pak, Inc. / A Business Unit of Patterson Pump Company, Toccoa, Georgia.
- 1-2** After carefully uncrating or unpacking, check the equipment against the shipping papers, and inspect for any damage incurred during shipment. Immediately notify the carrier of any damage or shortage found.
- 1-3** The type and sizing of the unit was built to meet requirements provided by the purchaser. Among the more important requirements are the following:
- Liquid pumped
 - Flow in gallons-per-minute
 - Temperature of liquid pumped degree Fahrenheit
 - Suction condition, pressure or lift
 - Discharge pressure
 - Power supply characteristics
 - Location
- 1-4** If any of the requirements change after the order was placed, we suggest that each change be reviewed with the factory.

CAUTION: Operation of the package under conditions different from the design requirements may void the warranty!

SECTION II – INSTALLATION

2-1 Location

Select a location for the package which will be clean, well ventilated, properly drained, and provide accessibility for inspection and maintenance. Outdoor installation may require protection from the elements, particularly freezing.

PACKAGE PUMPING SYSTEMS

- *** Installation
- *** Operation
- *** Maintenance

Read the entire manual before attempting to install, operate or repair this equipment.

Properly installed your Flo-Pak package will give you satisfactory and dependable service. We urge that you carefully read these step-by-step instructions to simplify any problems of installation, operation or repair.

Failure to read and comply with installation and operation instruction will void the responsibility of the manufacturer and may also result in bodily injury, as well as property damage.

This manual is intended to be a permanent part of your package installation and should be preserved in a convenient location for ready reference. If these instructions should become soiled, obtain a new copy from Flo-Pak. Be sure to include the package serial number you request.

2-2 Foundation

Concrete (reinforcement as necessary or required) is most widely used for the foundation. In sufficient mass it provides rigid support which minimizes deflection and vibration. It may be located on soil, structural steel or building floors, provided the combined weight of the package, grout and foundation does not exceed the allowable bearing load of the support. Allowable bearing loads of structural steel and floors can be obtained from engineering handbooks, building codes or local communities which give the recommended allowable bearing loads for different types of soil.

- 2-3** Before pouring, roughen the top surface to provide a good bond. Ordinarily the proportions used are 1 part cement to 3 parts sand and 4 parts medium aggregate.

2-4 If vibration or noise will be objectionable, as in office building, it may be advisable to use vibration dampeners between the package unit and foundation in conjunction with suction and discharge piping vibration suppressor.

2-5 Mounting

Set the package unit on the foundation base. Level the unit and check the alignment on the bearing frame units; tighten the foundation bolts.

2-6 Alignment Bearing Frame Units Only

Reliable, trouble-free and efficient operation of the unit depends on the correct alignment of the pumps and driver shafts. Misalignment may be the cause of:

- a. Noisy pump operation
- b. Vibration
- c. Premature bearing failure
- d. Excessive coupling wear

Note: Complete units are aligned at the factory. Experience has shown that all bases, no matter how rugged or deep in section, will twist during shipment. At the very least, the alignment must be checked after mounting.

Factors which may change the alignment of the unit after the initial installation:

- a. Settling of the foundation
- b. Springing of the base
- c. Piping strain
- d. Settling of the building
- e. Shift of pump driver on the foundation

2-7 Grouting

Grouting compensates for unevenness in the foundation and the base, as well as distributes the weight of the unit uniformly over the foundation. It also helps to prevent the unit from shifting after mounting. It is essential that the unit be expertly grouted by use of non-shrinking grout. Grout the unit as follows:

- a. Build a form of plywood or thin planking around the foundation to contain the grout. Support adequately to prevent deformation.

- b. Soak the top of the concrete pad thoroughly with water before grouting. Remove all surface water before pouring.
- c. A recommended mix of grout satisfactory for most applications is as follows:
 - 1. One part of normal Portland Cement – 94#
 - 2. One part of Embecco Cement – 100#
 - 3. One part of coarse clean sand – 100#
 - 4. One and one-half parts of ¼" pea gravel (1½ cu. Ft.)
 - 5. approximately 5 ½ gallons water
- d. Pour the grout into the base and, while pouring, tamp liberally in order to fill cavities and prevent air pockets. In order to prevent the base from shifting, grout 4" out from all sides of the base. Slant outside edges of the grout to prevent chipping.
- e. Approximately fourteen days after the grout has been poured or when the grout is thoroughly dried, apply an oil base paint to all exposed surfaces of the grout to prevent air and moisture from coming in contact with the grout.

2-8 Piping

The suction and discharge piping should be arranged for the most simple, direct layout and be of sufficient size and internally free of foreign material. The piping must never be pulled into position by the flange bolts. It must be independently supported and arranged in order to not induce any strain on the package.

Note: Piping should be cleaned and flushed prior to installing the package. A large number of packing, mechanical seals and seizure troubles of the pumps are due to improperly cleaned system.

2-9 Electricity

Connect the power supply to the package conforming to the National Electrical and local codes. Line voltage and wire capacity must match the rating stamped on the control panel nameplate.

- a. Only when the coupling halves are disconnected (frame mounted pumps) and the water supply is to the suction of the pumps, momentarily energize the panel and check that rotation of the pumps is correct by setting the hand-off-auto switch into the hand position.

- b. If the rotation is inaccurate, correct by changing any two of the three power leads.

SECTION III – LUBRICATION

3-1 Couplings

Couplings with rubber drive parts do not require lubrication; however, most couplings do require some form of lubrication. After completion of installation and alignment, and before operating the unit, lubricate couplings in accordance with the manufacturer's specific instruction contained in the package installation manual.

3-2 Ball Bearings

Reasonable care and proper lubrication of bearings will result in many years of service. The lubricant provides a film between the balls, separator and races, giving low friction and preventing excessive temperature rise and corrosion.

3-3 The normal life of ball bearings is terminated only by fatigue. Improper lubrication practices are the primary cause of failure. Good practice includes the following:

- a. Keep lubricant clean; provide and use a dust-tight cover on the storage container.
- b. Use the oldest lubricant first.
- c. Clean lubrication fittings before re-lubrication.
- d. Use clean dispensing equipment.
- e. Use the proper amount of lubricant. Too much grease results in churning and unnecessary power consumption, rapid heating to high temperatures which break down the grease.
- f. Use the correct lubricant. Grease Lithium Soap Base, meeting National Lubricating Grease Institute Grade 2 specifications. This has a safe operating temperature higher than 300 degrees Fahrenheit.

3-4 Operating Temperature

Use of the lubricants and procedures given in this manual will allow safe operation at bearing temperatures to 250 degrees Fahrenheit. Past experience, however, indicates the normal temperature will not exceed 250 degrees if the pumped fluid is well below that temperature.

- 3-5** A high normal operating temperature is not a sign of bearing failure. Normal temperatures vary with the seasons and the environment and may range from 0 to approximately 200 degrees Fahrenheit. A continuous rise from established normal operating temperature indicates trouble and probable failure of the bearings. Shut down the unit immediately. Disassemble, clean and inspect the bearings. Replace if required.

3-6 Re-Lubrication

Grease that has been in service does not “wear away.” It needs replacing only because of contamination by dust, metal particles, moisture or high temperature breakdown.

- a. Thoroughly clean greased fitting.
- b. Remove grease drain plug on equipment so equipped.
- c. Inject clean new grease.

SECTION IV – OPERATION

- 4-1** When making an initial start, after installation or major maintenance, check the following:

- a. Coupling alignment (if frame mounted).
- b. Bearing lubricant on pumps and drives.

- 4-2** Start the package as follows:

1. When possible, turn the pump shaft by hand to make sure parts do not bind.
2. Open suction valves.
3. Start drive in “hand” and check rotation. (Correct as necessary.)
4. With pump running in “hand” regulate system pressure by adjusting the pressure regulating valve. (See data sheet in manual.) Repeat this for all pumps on package.

SECTION V – MAINTENANCE

WARNING – DISCONNECT THE POWER TO ANY ROTATING OR ELECTRICAL COMPONENTS BEFORE STARTING ANY REPAIRS!

5-1 Regular consistent maintenance is the best way to avoid serious trouble which may require taking the unit out of service for extensive repair.

5-2 Bearings

It is essential to provide proper lubrication and keep bearings clean. Frequency of lubrication must be determined by experience as it depends upon bearing size, speed, operating conditions and location (environment). Table 1 should be used as a guide for grease re-lubrication.

<u>Operating Conditions</u>	<u>Lubricate</u>
Normal, 8-hour day operation. Area free of dust and damaging atmosphere.	Every six (6) months.
Severe, 24-hour day operation. Area with moderate dust and/or damaging atmosphere or outdoor service.	Every month.
Light, approximately 10-hour week. Area relatively free of dust and damaging atmosphere.	Every year.

5-3 Alignment – (Bearing frame unit only) – Check alignment yearly.

TABLE 2

<u>Problems</u>	<u>Probable Cause</u>	<u>Remedy</u>
Failure to deliver liquid or sufficient pressure.	Control valve not adjusted correctly.	Adjust control valve. (See valve manual.)
	Incorrect pump rotation.	Change rotation.
	Discharge head too high.	Check that all discharge valves are open and discharge line is free from obstructions. In some cases the installation needs to be altered or pump of suitable rating supplied.
	Impeller passages restricted.	Disassemble the pump and clean the impeller.
	Pump not up to speed.	Check for low motor voltage or motor overload.
	Worn wearing rings.	Replace worn parts.
	Damaged impeller.	Replace or repair impeller.
Overload of driver.	Total head lower than rating	Check suction and discharge pressure and determine the total dynamic head. If TDH is lower than rated, throttle discharge valve to rated TDH.
	Mechanical problem in pump or driver.	See if unit turns freely.
Vibration or noise.	Misalignment bearing (frame units only).	Realign unit.
	Worn ball bearing.	Replace bearings.
	Cracked foundation.	Replace foundation.
All pumps running lag units cycle off and back on again.	Control valve setting and start pressure switch not adjusted correctly in relation to one another.	Readjust.
	Too low setting on start delay timer.	Readjust.

**TABLE 2
(Continued)**

All pumps running lag units cycle off and back on again.	Package undersized for load.	Verify operating flow and head.
Low suction alarm tripping.	Low suction switch adjusted incorrectly or poorly.	Check adjustment.
	Actual low suction condition.	Check suction pressure with test gauge.
All other alarms.	Switches adjusted incorrectly.	Readjust.
	Actual alarm condition.	Verify and correct.
	Delay timer set too low.	Increase time delay.

5-4 Spare Parts

To keep delay to a minimum when package repairs are required, we suggest that the following spare parts be stocked:

Panel

- a. Spare set of fuses.
- b. Spare timer.
- c. Spare relay.
- d. Spare system pressure switch and suction pressure switch.

Pumps

- a. Spare mechanical seal for each size pump.
- b. Spare casing gasket for each size pump.
- c. Spare shaft sleeve for each size pump.
- d. Spare impeller for each size pump.

5-5 To obtain quick and accurate service when ordering spare parts, provide the following information:

- 1. Package serial number.
- 2. The name and number of parts shown on the data provided for the individual component.
- 3. Quantity required on each item.

Aid may be obtained from the Flo-Pak representative in your area or from the factory.

Flo-Pak, Inc.
P.O. Box 790
Toccoa, Georgia 30577
Telephone: 706-886-2101
Fax: 706-886-0023
www.flo-pak.com

A Business Unit of Patterson Pump Company

5/28/04



PUMP COMPANY / A Subsidiary of The Gorman -Rupp Co.
 P.O. Box 790 / Toccoa, Georgia 30577 / (706) 886-2101 / FAX (706) 886-0023
 www.pattersonpumps.com

General Pump Inspection and Maintenance Schedule Packaged Pump Systems

**Any additional inspections, maintenance, or tests required by NFPA- Standards for fire pumps are excluded.
 Refer to NFPA Standards for additional requirements for fire pumps.**

Actions required only for specific pump types are so noted.
 The symbol (■) used in the table below indicates that the action indicated may not be applicable to a specific pump of a particular type.
 For more information regarding inspection and maintenance requirements refer to the Patterson O & M manual supplied with the pump.
 Contact Patterson Pump Company if assistance is needed to determine the inspection and service requirements for a specific pump.

Inspect (✓) or service (●) at the indicated calendar time or run time interval – whichever comes first	4 hours	Routinely	Monthly	2000 hours or 3 months	4000 hours or 6 months	8000 hours or 12 months
Replenish grease lubricated sleeve bearing grease per the O & M manual using the manual grease lubricator. Perform every 3 months while idle. (vertical wet pit pumps so equipped) ■	●					
Unusual noise		✓				
Unusual vibration		✓				
Unusual temperature		✓				
Leaks in pump or piping		✓				
Pressure gauge readings		✓				
Visual inspection of equipment general condition		✓				
Anytime a pump is opened, inspect the running clearances and restore them to original specifications if the running clearances have doubled (adjust ring clearances if so supplied or install new wear rings)		✓ ●				
Anytime a pump is opened, inspect the impeller for corrosion or excessive wear.		✓ ●				
Packing box – verify slight leakage (if excessive, adjust gland or seal water valve; replace packing if required) ■		✓ ●				
Mechanical seal (should be no leakage) ■		✓				
Drain lines are working properly ■		✓				
Coupling integrity ■		✓				
Drive shaft integrity ■		✓				
Verify proper operation of oil drip lubricator (vertical wet pit pumps so equipped) ■			✓			
Verify proper operation of automatic grease lubricator (vertical wet pit pumps so equipped) ■			✓			
Operate the pump (note – for vertical wet pit pumps first verify proper lubrication)			✓			
Tightness of foundation and hold-down bolts				✓		
Check coupling alignment and integrity (maintain records) ■				✓		
Add grease to pump anti-friction bearings (maintain records) ■				●		
Add grease to universal joint shafting u-joint bearings, anti-friction steady bearings (maintain records) ■				●		
Add grease to coupling (maintain records) ■				●		
Change anti-friction bearing oil (maintain records) ■				●		
Replace packing (all packing; not just the outermost ring) ■					●	
Clean and oil gland bolts (packed pumps) ■					●	
Verify free movement of packing glands (packed pumps) ■					✓	
Universal joint shafting and steady bearings wear check (replace bearings if required) ■					✓ ●	
Clean packing box						●
Check and flush seal water and drain piping						●
Perform a comparative field test (flow, pressures, and power) with calibrated instruments. Restore internal running clearances if results are unsatisfactory (install new wear rings).						✓ ●
Perform a comparative vibration test						✓
Remove packing and inspect sleeve(s). Replace if worn. (packed pumps) ■						✓ ●
Realign coupled pumps (maintain records) ■						●
Remove pump handhole covers and inspect impeller for corrosion and excessive wear (sewage pumps) ■						✓
Remove handhole covers to inspect the wear ring clearances. When the wear ring clearances have doubled, adjust the ring clearances to original specifications if so supplied or install new wear rings (sewage pumps). ■						✓ ●
Examine running clearance between propeller and propeller housing. When the running clearance has doubled, repair or replace the housing, housing liner, or propeller as appropriate. (model AFV axial flow pumps) ■						✓ ●
Inspect the impeller running clearance. Inspect the impeller housing for excessive wear. If the wear is not excessive, perform impeller adjustment. If the wear is excessive, repair or replace the impeller housing. (open impeller mixed flow pumps, such as models SAF, SAFV, SAFH, or TMF) ■						✓ ●
Inspect batteries & battery charger for proper charge.			✓			
Observe operation of fans & dampers such that the fans & dampers operate at set temperature, and damper opens upon operation of the diesel engine.			✓			
Jockey Pump – See manual for specific jockey maintenance requirements.			✓			
Engine Maintenance (Belts / Filters / Oil / Fuel Strainer) [See O&M manual for Engine]			✓ ●			
Replace any worn caulk around pipe exits on buildings.					✓	
Building Heater - Inspect for proper operation.					✓	
Inspect operation of all valves in system.					✓	
Lights (Outside, Inside, Emergency) – Inspect for proper operation.					✓	



Sequence of Operation

Duplex Constant Speed Booster

Rev. 1 02/08/16

Basic Operation

The pumps are started and stopped according to discharge pressure.

The “Discharge Pressure Set-point” is the set-point pressure desired to be maintained at the discharge header. This should be the same as the pressure which is set for each pump(s) pressure reducing valve.

The start and stop pressure set-points for the lead and lag pumps are “deviations” below the “Discharge Pressure Set-point”.

The lead pump will start after an adjustable time delay when the discharge pressure drops to the start lead pressure set-point.

The lag pump will start after an adjustable time delay when the discharge pressure drops to the start lag pump pressure set-point or if the optional flow sensor is supplied, when the flow rate meets or exceeds the start lag pump set-point.

Once a pump has started, it will run for an adjustable minimum run time. The factory default minimum run time is set to 10 minutes.

Shutdown will occur in reverse order according to the starting sequence.

The lag pump will stop when the discharge pressure has risen to the stop lag pump set-point and its minimum run timer has expired and if the optional flow sensor is supplied, when the flow rate drops to or below the stop lag pump set-point.

The lead pump will stop when the discharge pressure has risen to the stop lead pump set-point, its minimum run timer has expired, the lag pump has stopped and there is no flow as sensed by the optional no flow switch.

An optional no-flow switch can be provided to hold the lead pump on as long as there is 5 or more GPM still flowing through the system. This prevents unnecessary “cycling” of the lead pump.

Equal sized pumps are alternated every time all equal pumps have stopped (duty cycle alternation) or after 24 hours whichever occurs first. The hour for which the 24 hour alternation change occurs can be selected by the operator.

Once the system piping has been filled and the pressure reducing valves have been adjusted to the desired pressure, the operator simply performs the following:

Set the HOA switches in the automatic position.

Set the Discharge Pressure Set-point to match the pressure as set by the pressure reducing valves.

Set the starting and stopping set-point pressure deviations of the lead and lag pumps.

Set the starting and stopping flow rate set-points of the lag pump if optional flow sensing is provided.

Low Suction Shutdown

In the event of low suction (supply) pressure, the pumps will be stopped and the Low Suction Pressure alarm will be initiated after an adjustable time delay. The alarm will automatically reset after 10 seconds (adjustable) if configured for auto reset or will require a manual reset if the alarm is configured for manual reset when the pressure rises above the alarm set-point. Once reset, the pumps will be re-enabled.

High Suction Shutdown

In the event of high suction (supply) pressure, the pumps will be stopped and the High Suction Pressure alarm will be initiated

after an adjustable time delay. The alarm will automatically reset after 10 seconds (adjustable) if configured for auto reset or will require a manual reset if the alarm is configured for manual reset when the pressure drops below the alarm set-point. Once reset, the pumps will be re-enabled.

Low Discharge Alarm

In the event of a low discharge pressure condition, the Low Discharge Pressure alarm will be initiated after an adjustable time delay. The alarm will automatically reset after 10 seconds (adjustable) if configured for auto reset or will require a manual reset if the alarm is configured for manual reset when the discharge pressure rises above the alarm set-point.

High Discharge Shutdown

In the event of a high discharge pressure condition, the pumps will be stopped and the High Discharge Pressure alarm will be initiated after an adjustable time delay. The alarm will automatically reset after 10 seconds (adjustable) if configured for auto reset or will require a manual reset if the alarm is configured for manual reset when the discharge pressure drops below the alarm set-point. Once the alarm is reset, the pumps will be re-enabled.

Irregular Power (Optional)

In the event of an irregular power condition as sensed by a phase monitor, the pumps will be stopped and the Irregular Power alarm will be initiated. Once the irregular power condition has been corrected, the pumps will be automatically re-enabled and the alarm will be reset.

Discharge Pressure Transducer Failure

In the event of discharge pressure transducer failure, the pumps will be stopped. The operator will be required to start the pumps manually (Hand).

Suction Pressure Transducer Failure

In the event of suction pressure transducer failure, the pumps will be stopped and the PLC will remove this failed sensor from operation. The operator will be able to start pump 1 manually in an emergency only using the On/Auto selector located inside of the control panel enclosure. When pump 1 is started in this manner, there are no pump or system shutdown safeties. The operator must monitor the system continuously when operating pump 1 in the backup start mode to prevent damage to the system, the pump or other devices downstream of the system. The operator must install a jumper across two terminal blocks in order to enable the backup selector switch.

PLC Failure

In the event of programmable logic controller (PLC) failure, the pumps will stop. The operator will be able to start pump 1 manually in an emergency only using the On/Auto selector located inside of the control panel enclosure. When pump 1 is started in this manner, there are no pump or system shutdown safeties. The operator must monitor the system continuously when operating pump 1 in the backup start mode to prevent damage to the system, the pump or other devices downstream of the system. The operator must install a jumper across two terminal blocks in order to enable the backup selector switch.

HMI (Operator Interface) Failure

In the event that the HMI should fail, the PLC will continue to operate the system based on the last states for which the PLC was adjusted via the HMI. For example, if the HOA switches were left in the "auto" position, the PLC will continue to start and stop the pumps as if the HMI had never failed. Should the operator be required to stop the pumps, the individual pump MSPs can be opened or the main power disconnect can be opened to de-energize the system.

Pump Failure

If the pump fails to run when called to start, the PLC will ignore the failed pump in the starting/running sequence and will start the remaining pump in its place. The PLC will put the failed pump back into the starting/running sequence once the call to run failure has been cleared.

Operator Interface

The HMI is menu button driven for ease of navigation. Following are some of the main screens.

"Menu" is the starting point for all screens.

"Main" displays the normal operating data screen which includes HOA switches, running lights, pressure, etc.

"Setup Menu" allows the operator adjust start/stop set-points, timers, etc.

“Alarms” displays the alarms screen. The operator can touch an alarm lamp to bring up information about a specific alarm.

Alarms that require a manual reset are reset via the “Manual Reset” button located on the alarms screen.

Communication

The control panel provides one dry normally open contact for system common alarm.



Discharge 94 PSIG	Suction 21 PSIG	Setpoint 94 PSIG		Stop Pumps
----------------------	--------------------	---------------------	--	---------------

Off	Off
Hand Off Auto	Hand Off Auto
P1	P2

System Enabled	A 1-2	Menu	Silence
-------------------	-------	------	---------

Main	Sequence Selection	Trending	
Large Pressure Display	Alarms	Date and Time	
Pump Elapsed Time	I/O Monitor	System Info	
	Setup Menu		
	Logout		
	PPTECH		Silence

Large Pressure Display

Discharge 93 PSIG	Suction 20 PSIG	Setpoint 94 PSIG			Stop Pumps
Discharge Pressure					
93 PSIG					
Suction Pressure					
20 PSIG					
System Enabled	A 2-1		Alarms	Menu	Silence

Pump Run Time

Discharge 97 PSIG	Suction 20 PSIG	Setpoint 94 PSIG		Stop Pumps
P1 0.0 Hrs		P2 0.0 Hrs		
System Enabled	A 2-1	Alarms	Menu	Silence

Sequence Selection

Discharge 97 PSIG	Suction 20 PSIG	Setpoint 94 PSIG		
----------------------	--------------------	---------------------	--	--

Stop Pumps

Sequence Selection



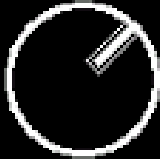

2-1

1-2 Auto



System Enabled	A 2-1	Alarms	Menu	Silence
-----------------------	-------	---------------	------	----------------

Alarms

High Disch. Pressure 	High Suction Pressure 			Stop Pumps
Low Disch. Pressure 	Low Suction Pressure 	P1 Failed	P2 Failed	
Discharge Sensor Fault	Suction Sensor Fault	P1 Run Failure	P2 Run Failure	
Defaults Loaded				
	Alarm History	Manual Reset	Menu	Silence

Alarms History

1 / 7 / 2016		Thursday		Stop Pumps
15 : 41 : 5				
Message	Date	Time		
P1 HOA In Auto Position	01/07/16	15:37:16	▲	
P2 HOA In Auto Position	01/07/16	15:37:16	▲	
P1 Failure	01/07/16	15:38:26	▲	
P1 Call to Run Failure	01/07/16	15:38:26		
P2 Failure	01/07/16	15:38:31		
P2 Call to Run Failure	01/07/16	15:38:31		
▶ Manual Reset Depressed	01/07/16	15:40:12		
			▼	
			▼	

Back **Menu** **Silence**

I/O Monitoring

Discharge 96 PSIG	Suction 19 PSIG	Setpoint 94 PSIG		Stop Pumps
I/O Monitor				
Discrete Inputs		Discrete Outputs		Analog Inputs
<input type="checkbox"/> DI0	<input type="checkbox"/> DI7	<input type="checkbox"/> DO0	<input type="checkbox"/> DO5	9106 A10
<input type="checkbox"/> DI1	<input type="checkbox"/> DI8	<input type="checkbox"/> DO1	<input type="checkbox"/> DO6	5025 A11
<input type="checkbox"/> DI2	<input type="checkbox"/> DI9	<input type="checkbox"/> DO2	<input type="checkbox"/> DO7	0 A12
<input checked="" type="checkbox"/> DI3	<input type="checkbox"/> DI10	<input type="checkbox"/> DO3	<input type="checkbox"/> DO8	0 A13
<input type="checkbox"/> DI4	<input type="checkbox"/> DI11	<input type="checkbox"/> DO4	<input type="checkbox"/> DO9	
<input type="checkbox"/> DI5	<input type="checkbox"/> DI12			
<input type="checkbox"/> DI6	<input type="checkbox"/> DI13			
First Scan OK		Menu	Silence	

Pressure Trend Screen

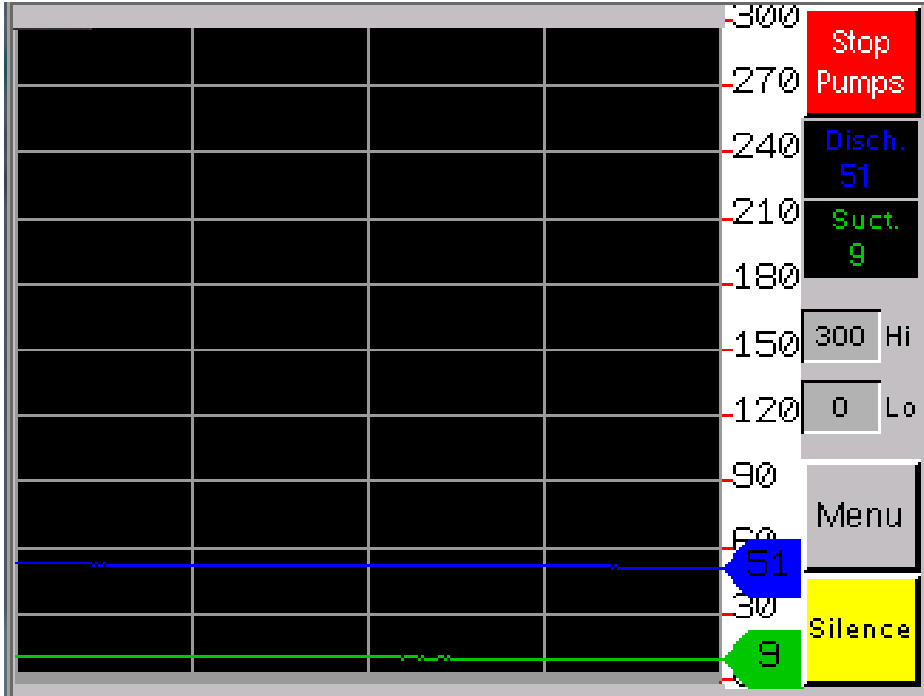

Discharge 95 PSIG	Suction 19 PSIG	Setpoint 94 PSIG		Stop Pumps
----------------------	--------------------	---------------------	--	-----------------------

Current Date and Time
(PLC Date/Time)

1 / 7 / 2016
15 : 41 : 56

Thursday

System Enabled	A 2-1	Menu	Silence
---------------------------	--------------	------	----------------

Setup Menu
(Logged in)

Goal Setpoint	Clock	Alternation Hour	Stop Pumps
Lead Pump Start / Stop	System Enable/Disable		
Lag 1 Pump Start / Stop	Pump Exerciser	Recipes	Menu
	HM Config		
Minimum Run Timers	Analog Setup		
Pump Fail Time Delays			
Pump Elapsed Timer Reset	Alarm Setup Menu		Silence

Setup (Goal Set-point)

Discharge 94 PSIG	Suction 18 PSIG	Setpoint 94 PSIG		Stop Pumps
----------------------	--------------------	---------------------	--	---------------

Goal Set-point 94 PSI
(Enter Pressure Equal To Pump PRV Settings)

Setup
Menu

Menu

Silence

Setup (Lead Pump)

Discharge	Suction	Setpoint	
94 PSIG	18 PSIG	94 PSIG	
Start Lead Pump 1 PSIG Below Goal Setpoint			
Stop Lead Pump 0 PSIG Below Goal Setpoint			
Lead Pump Start Delay 1 Sec.			









Setup (Lag 1 Pump)

Discharge	Suction	Setpoint	
99 PSIG	18 PSIG	94 PSIG	

Start Lag 1 Pump **2** PSIG Below Goal Setpoint

Stop Lag 1 Pump **0** PSIG Below Goal Setpoint

Lag 1 Pump Pressure Start Delay **15** Sec.

Stop Pumps

Setup Menu

Menu

Silence

Setup (Pump Minimum Run Time)

Discharge	Suction	Setpoint		
99 PSIG	18 PSIG	94 PSIG		Stop Pumps
Pump 1 Minimum Run Time		600	Sec.	
Pump 2 Minimum Run Time		600	Sec.	
				Setup Menu
				Menu
				Silence

Setup (Pump Call to Run Failure)

Discharge	Suction	Setpoint		
99 PSIG	18 PSIG	94 PSIG		Stop Pumps
Pump 1 Call To Run Fail Delay			5	Sec.
Pump 2 Call To Run Fail Delay			5	Sec.
				Setup Menu
				Menu
				Silence

Setup (Pump Elapsed Time Reset)

Discharge 99 PSIG	Suction 18 PSIG	Setpoint 94 PSIG		Stop Pumps
----------------------	--------------------	---------------------	--	---------------

Pump Elapsed Timer Reset

P1 0.0 Hrs	P2 0.0 Hrs
---------------	---------------

Reset Reset

Setup Menu	Menu	Silence
---------------	------	---------

Current Date and Time

1 / 7 / 2016

15 : 45 : 32

Thursday

New Date and Time

Month Day Year

0 0 0

Hour Minutes Seconds

0 0 0

Stop Pumps

Setup Menu

Menu

Silence

System Enabled

Set New Date and Time

System Enable/Disable Time (Hour 0-23)			Stop Pumps
	Enable	Disable	
Sunday	0	0	Setup Menu Menu Silence
Monday	0	0	
Tuesday	0	0	
Wednesday	0	0	
Thursday	0	0	
Friday	0	0	
Saturday	0	0	
System Enabled	Equal Times For Full Time Enable		

Setup (Pump Exerciser)

Pump Exerciser

Stop Pumps

Pump Exerciser Disabled

Enable Exerciser Disable Exerciser

Hour To Start Exerciser 4 (Hour 0-23)

Exerciser Duration 60 Seconds

Menu

Silence

Setup (Analog Input 0)

Discharge 97 PSIG	Suction 17 PSIG	Setpoint 94 PSIG		Stop Pumps
Analog Input 0 Scaling (Discharge Pressure)				
Analog Input 0 Input Low		4.000	ma	
Analog Input 0 Input High		20.000	ma	
Analog Input 0 Output Low		0	PSIG	Setup Menu
Analog Input 0 Output High		300	PSIG	Menu
Analog Input 0 Fail Level		2.000	ma	Next Silence

Setup (Analog Input 1)

Discharge 97 PSIG	Suction 17 PSIG	Setpoint 94 PSIG		Stop Pumps
Analog Input 1 Scaling (Suction Pressure)				
Analog Input 1 Input Low		4.000	ma	
Analog Input 1 Input High		20.000	ma	
Analog Input 1 Output Low		0	PSIG	Setup Menu
Analog Input 1 Output High		300	PSIG	Menu
Analog Input 1 Fail Level		2.000	ma	Prev Silence

Pressure Alarms Setup Menu

The interface is a black rectangular panel with several colored buttons. On the left side, there is a vertical stack of four blue buttons: 'High Discharge', 'Low Discharge', 'High Suction', and 'Low Suction'. On the right side, there is a vertical stack of four buttons: a red 'Stop Pumps' button at the top, followed by a blue 'Setup Menu' button, a grey 'Menu' button, and a yellow 'Silence' button at the bottom.

Setup (High Discharge Alarm Setup)

Discharge	Suction	Setpoint		
96 PSIG	17 PSIG	94 PSIG		Stop Pumps
High Discharge Setpoint is.....		20	PSIG	
Above Setpoint				
High Discharge Alarm Delay		10	Sec.	
High Discharge Alarm Auto		10	Sec.	
Reset Delay				Setup Menu
Reset Type: Auto				Menu
Manual	Auto	Alarm Setup Menu		Silence

Setup (Low Discharge Alarm Setup)

Discharge 96 PSIG	Suction 17 PSIG	Setpoint 94 PSIG		Stop Pumps
Low Discharge Setpoint is.....		10	PSIG	
Below Discharge Setpoint				
Low Discharge Alarm Delay		30	Sec.	
Low Discharge Auto Reset Delay		10	Sec.	Setup Menu
Reset Type: Auto				Menu
Manual	Auto	Alarm Setup Menu		Silence

Setup (High Suction Alarm Setup)

Discharge	Suction	Setpoint		
96 PSIG	17 PSIG	94 PSIG		Stop Pumps
High Suction Setpoint		100	PSIG	
High Suction Alarm Delay		10	Sec.	
High Suction Alarm Auto Reset Delay		10	Sec.	
Reset Type: Auto				Setup Menu
				Menu
Manual	Auto	Alarm Setup Menu	Silence	

Setup (Low Suction Alarm Setup)

Discharge 96 PSIG	Suction 17 PSIG	Setpoint 94 PSIG		Stop Pumps
Low Suction Setpoint				5 PSIG
Low Suction Alarm Delay				10 Sec.
Low Suction Alarm Auto Reset Delay				10 Sec.
Reset Type: Auto				Setup Menu
				Menu
Manual	Auto	Alarm Setup Menu	Silence	

Setup (24 Hour Alternation Override)

24 Hour Alternation Override Time
(Hour 0-23)

1

Stop Pumps

Setup Menu

Menu

Silence

Setup (Set-point Recipes)

Recipe Group		RecipeGroup1	▼
Recipe		Defaults	▼
<input type="checkbox"/> Send	SerialNumber	C014437%	▲
	GOAL_SP	94	
<input type="checkbox"/> Save	LEAD_START_DEVIATION	1	
	LEAD_STOP_DEVIATION	0	
<input type="checkbox"/> Snapshot	LEAD_CALL_DELAY	1	
	LAG_1_START_DEVIATION	2	
<input type="checkbox"/> Delete	LAG_1_STOP_DEVIATION	0	▼

Back

Duplex Amperage Chart

MODEL	208v-3-60hz		
	Pump(s) FLA		System MCA
	P1	P2	
DAP-1-2	7.5	7.5	19
DAP-1-3	10.6	10.6	26
DAP-2-3	10.6	10.6	26
DAP-1-5	16.7	16.7	40
DAP-2-5	16.7	16.7	40
DAP-2-7	24.2	24.2	56
DAP-3-5	16.7	16.7	40
DAP-3-7	24.2	24.2	56
DAP-3-10	30.8	30.8	71
DAP-3-15	46.2	46.2	106
DAP-3-20	59.4	59.4	136
DAP-4-10	30.8	30.8	71
DAP-4-15	46.2	46.2	106
DAP-4-20	59.4	59.4	136
DAP-4-25	74.8	74.8	170

230v-3-60hz		
Pump(s) FLA		System MCA
P1	P2	
6.8	6.8	17
9.6	9.6	23
9.6	9.6	23
15.2	15.2	36
15.2	15.2	36
22	22	51
15.2	15.2	36
22	22	51
28	28	65
42	42	96
54	54	123
28	28	65
42	42	96
54	54	123
68	68	155

460v-3-60hz		
Pump(s) FLA		System MCA
P1	P2	
3.4	3.4	9
4.8	4.8	12
4.8	4.8	12
7.6	7.6	18
7.6	7.6	18
11	11	26
7.6	7.6	18
11	11	26
14	14	33
21	21	48
27	27	62
14	14	33
21	21	48
27	27	62
34	34	78

380v-3-50hz		
Pump(s) FLA		System MCA
P1	P2	
4.3	4.3	11
6	6	15
6	6	15
9.6	9.6	23
9.6	9.6	23
13.9	13.9	33
9.6	9.6	23
13.9	13.9	33
17.7	17.7	41
26.5	26.5	61
34.1	34.1	78
17.7	17.7	41
26.5	26.5	61
34.1	34.1	78
42.9	42.9	98



Range of product	Zelio Control
Product or component type	Modular measurement and control relays
Relay type	Control relay
Product specific application	For 3-phase supply
Relay name	RM17TG
Relay monitored parameters	Asymmetry Phase failure detection Phase sequence
Switching capacity in VA	1250 VA

Maximum switching voltage	250 V DC 250 V AC
Minimum switching current	10 mA at 5 V DC
[Us] rated supply voltage	208...480 V AC 3 phases
Supply voltage limits	183...528 V AC
Control circuit voltage limits	- 12 %, + 10 % Un
Power consumption in VA	<= 22 VA 400 V AC 50 Hz
Voltage detection threshold	< 100 V for phase failure AC
Control circuit frequency	50...60 Hz +/- 10 %
Output contacts	1 C/O
Nominal output current	5 A
Delay at power up	<= 650 ms
Voltage range	183...528 V
Response time	<= 130 ms in the event of a fault
Marking	CE : 73/23/EEC CE : EMC 89/336/EEC
Overvoltage category	III conforming to IEC 60664-1
Insulation resistance	> 500 MOhm at 500 V DC conforming to IEC 60664-1 > 500 MOhm at 500 V DC conforming to IEC 60255-5
[Ui] rated insulation voltage	400 V conforming to IEC 60664-1
Supply frequency	50/60 Hz +/- 10 %
Operating position	Any position without
Electrical connection	2 conductors cable 0.5...2.5 mm ² AWG20...AWG14 solid without cable end conforming to IEC 60947-1 2 conductors cable 0.2...1.5 mm ² AWG24...AWG16 flexible with cable end conforming to IEC 60947-1 1 conductor cable 0.5...4 mm ² AWG20...AWG11 solid without cable end conforming to IEC 60947-1 1 conductor cable 0.2...2.5 mm ² AWG24...AWG12 flexible with cable end conforming to IEC 60947-1
Tightening torque	0.6...1 N.m conforming to IEC 60947-1
Housing material	Self-extinguishing plastic
Status LED	1 LED yellow for relay
Mounting support	35 mm symmetrical DIN rail conforming to EN/IEC 60715
Electrical durability	100000 cycles
Mechanical durability	<= 30000000 cycles
Operating rate	<= 360 operations/hour under full load

Utilisation category	DC-13 conforming to IEC 60947-5-1 DC-12 conforming to IEC 60947-5-1 AC-15 conforming to IEC 60947-5-1 AC-14 conforming to IEC 60947-5-1 AC-13 conforming to IEC 60947-5-1 AC-12 conforming to IEC 60947-5-1
Width	17.5 mm
Product weight	0.13 kg

Environment

Electromagnetic compatibility	Immunity for industrial environments conforming to EN/IEC 61000-6-2 Emission standard for residential, commercial and light-industrial environments conforming to EN/IEC 61000-6-3 Emission standard for industrial environments conforming to EN/IEC 61000-6-4
Standards	EN/IEC 60255-1
Product certifications	CSA C-Tick GL GOST UL
Ambient air temperature for storage	-40...70 °C
Ambient air temperature for operation	-20...50 °C
Relative humidity	95 % at 55 °C conforming to IEC 60068-2-30
Vibration resistance	1 gn (f = 57.6...150 Hz) conforming to IEC 60068-2-6/IEC 60255-21-1 0.35 mm (f = 5...57.6 Hz) conforming to IEC 60068-2-6/IEC 60255-21-1
Shock resistance	15 gn for 11 ms conforming to IEC 60255-21-1
IP degree of protection	IP30 (casing) conforming to IEC 60529 IP20 (terminals) conforming to IEC 60529
Pollution degree	3 conforming to IEC 60664-1
Dielectric test voltage	2 kV 1 min AC 50 Hz
Non-dissipating shock wave	4 kV

Contractual warranty

Period	18 months
--------	-----------

3-Phase Supply Control Relays

Dimensions and Mounting

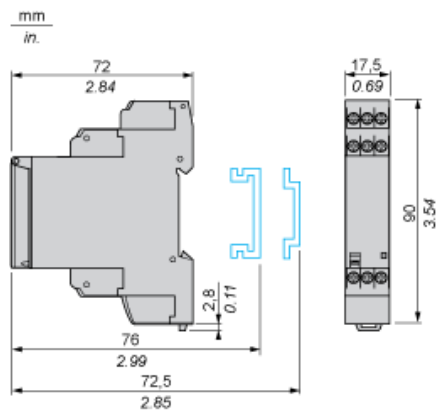

3-Phase Supply Control Relays

Wiring Diagram

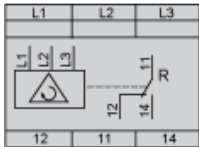

Application Scheme

Example

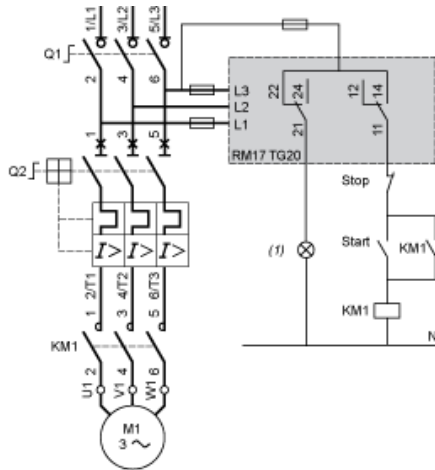

(1) Fault

Function Diagram

Phase Sequence Control and Total Loss of Phase Detection

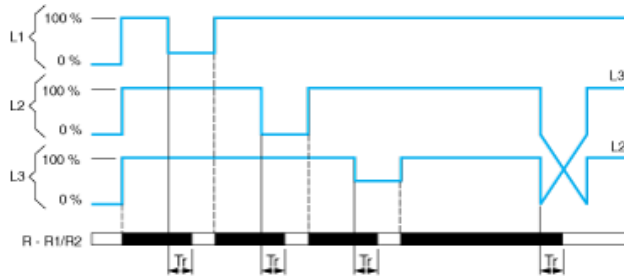

- Tr Response time on appearance of a fault
 - L1, Phases of the supply voltage monitored
 - L2,
 - L3
 - R - Output relay(s), depending on the product reference
 - R1/
 - R2
- Relay status: black color = energized.



SDSA3650 Series 001
Secondary Surge Arrester
Apartarrayos secundario
SDSA3650 serie 001
Suppresseur de surtensions secondaires
SDSA3650, série 001



Retain for future use. / Conservar para uso futuro. / À conserver pour usage ultérieur.

INTRODUCTION

The SDSA3650 Secondary Surge Arrester is designed and listed for indoor or outdoor installations and surge protection of three-phase grounded electrical services up to 600 Vac.

NOTE: Do not use on ungrounded systems. Use on solidly grounded systems only.

PRECAUTIONS

INTRODUCCIÓN

El apartarrayos secundario SDSA3650 ha sido diseñado y está registrado para ser instalado en interiores o en exteriores y proporcionar protección contra sobretensiones a acometidas eléctricas de tres fases, conectadas a tierra, de hasta 600 V~ (ca).

NOTA: No lo utilice en sistemas no puestos a tierra. Utilícelo sólo en sistemas puestos directamente a tierra.

PRECAUCIONES

INTRODUCTION

Le suppresseur de surtensions secondaires SDSA3650 est conçu et répertorié pour les installations intérieures et extérieures et pour la protection contre les surtensions de branchements électriques triphasés mis à la terre jusqu'à 600 Vca.

REMARQUE : Ne pas utiliser sur des systèmes non mis à la terre. À utiliser uniquement dans un système avec mise à la terre directe.

PRÉCAUTIONS

⚠ DANGER / PELIGRO / DANGER

HAZARD OF ELECTRIC SHOCK, EXPLOSION, OR ARC FLASH

- Apply appropriate personal protective equipment (PPE) and follow safe electrical work practices. See NFPA 70E.
- This equipment must only be installed and serviced by qualified electrical personnel.
- Turn off all power supplying this equipment before working on or inside equipment.
- Always use a properly rated voltage sensing device to confirm power is off.
- Replace all devices, doors and covers before turning on power to this equipment.

Failure to follow this instruction will result in death or serious injury.

PELIGRO DE DESCARGA ELÉCTRICA, EXPLOSIÓN O DESTELLO POR ARQUEO

- Utilice equipo de protección personal (EPP) apropiado y siga las prácticas de seguridad eléctrica establecidas por su Compañía, consulte la norma 70E de NFPA.
- Solamente el personal eléctrico especializado deberá instalar y prestar servicio de mantenimiento a este equipo.
- Desenergice el equipo antes de realizar cualquier trabajo en él.
- Siempre utilice un dispositivo detector de tensión nominal adecuado para confirmar la desenergización del equipo.
- Vuelva a colocar todos los dispositivos, las puertas y las cubiertas antes de volver a energizar el equipo.

El incumplimiento de esta instrucción podrá causar la muerte o lesiones serias.

RISQUE D'ÉLECTROCUTION, D'EXPLOSION OU D'ÉCLAIR D'ARC

- Portez un équipement de protection personnelle (ÉPP) approprié et observez les méthodes de travail électrique sécuritaire. Voir NFPA 70E.
- Seul un personnel qualifié doit effectuer l'installation et l'entretien de cet appareil.
- Couper l'alimentation de l'appareil avant d'y travailler.
- Utilisez toujours un dispositif de détection de tension ayant une valeur nominale appropriée pour vous assurer que l'alimentation est coupée.
- Remplacez tous les dispositifs, les portes et les couvercles avant de mettre l'appareil sous tension.

Si cette directive n'est pas respectée, cela entraînera la mort ou des blessures graves.

CAUTION / PRECAUCIÓN / ATTENTION

HAZARD OF EQUIPMENT DAMAGE.

Megger® or hi-potential tests will damage this surge protective device. Turn off all power supplying the equipment and isolate the surge protective device before testing.

Failure to follow this precaution can result in equipment damage.

PELIGRO DE DAÑO AL EQUIPO

Las pruebas de potencial aplicado o con Megger® dañarán el dispositivo de protección contra sobretensiones transitorias. Desenergice el equipo y aisle el dispositivo de protección contra sobretensiones transitorias antes de realizar cualquier prueba.

El incumplimiento de esta instrucción puede causar daño al equipo.

RISQUE DE DOMMAGES MATÉRIELS

Les essais de rupture diélectrique ou avec Megger® endommageront le dispositif de protection contre les surtensions. Coupez l'alimentation de l'appareil et isolez le dispositif de protection contre les surtensions avant de procéder à l'essai.

Si cette directive n'est pas respectée, cela peut entraîner des dommages matériels.

INSTALLATION

1. Turn off all power supplying this equipment before working on or inside equipment.
2. Confirm SDSA is rated for your system by comparing voltage measurements to the Line Voltage (L-L, L-N) on the product label. See Figure 1.

INSTALACIÓN

1. Desenergice el equipo antes de realizar cualquier trabajo en él.
2. Asegúrese de que el SDSA sea adecuado para su sistema comparando las mediciones de tensión en la tensión de línea (L-L, L-N), especificadas en la etiqueta del producto. Vea la figura 1.

INSTALLATION

1. Couper l'alimentation de l'appareil avant d'y travailler.
2. S'assurer que le SDSA est de la valeur nominale convenant à votre système en comparant les mesures de tension à la tension de la ligne (L-L, L-N) sur l'étiquette du produit. Voir la figure 1.

FIG. 1 : Wiring Diagrams / Diagramas de cableado / Schémas de câblage

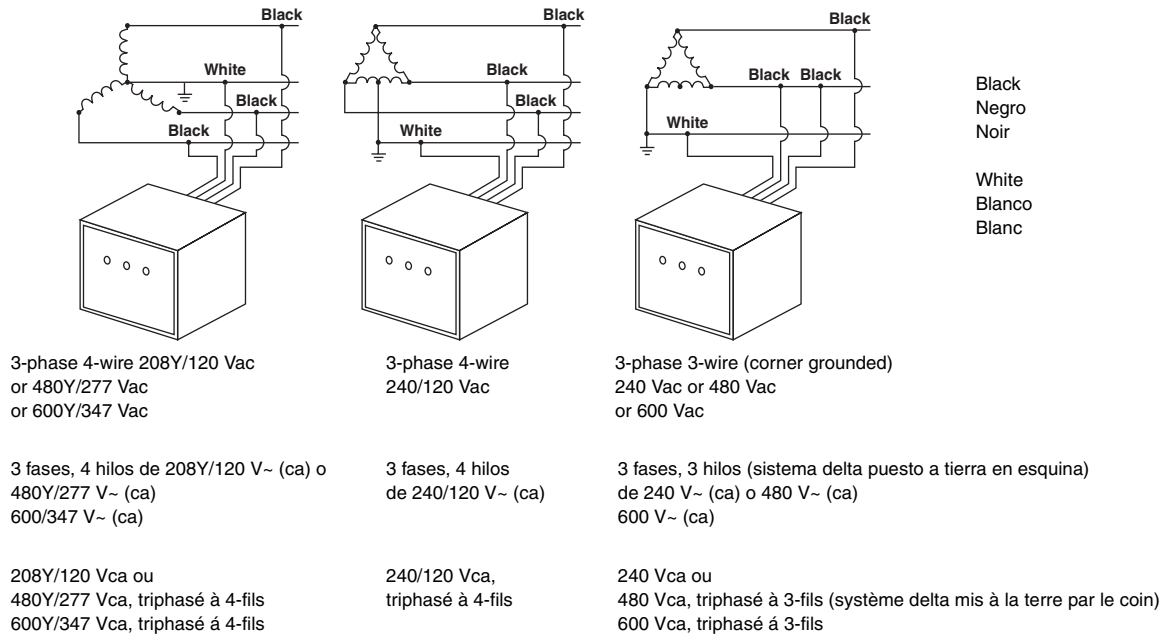

- | | | |
|--|---|--|
| <p>3. Install in accordance with article 280 of the National Electric Code®. See Figure 2.</p> | <p>3. Realice la instalación de acuerdo con lo especificado en el artículo 280 del Código nacional eléctrico de EUA (NEC) y NOM-001. Vea la figura 2.</p> | <p>3. Installer conformément à l'article 280 du Code national de l'électricité (NEC; É.-U.). Voir la figure 2.</p> |
|--|---|--|

FIG. 2 : Mounting SDSA Unit / Montaje de la unidad SDSA / Montage de l'unité SDSA

NOTE: The secondary surge arrester must be installed in an accessible location (not within walls).

NOTA: El apartarrayos secundario deberá ser instalado en una ubicación accesible (no encerrado)

REMARQUE : Le supresseur de surtensions secondaires doit être installé dans un emplacement accessible (non à l'intérieur de cloisons).

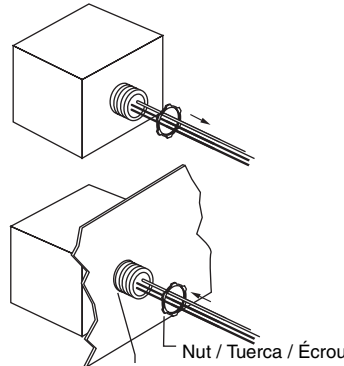

0.5 in. [13 mm] knockout (trade size)
Actual hole size .875 in. [22 mm]

Disco removible de 13 mm (0,5 pulg), tamaño comercial
Tamaño real del agujero: 22 mm (0,875 pulg)

Débouchure de 13 mm [0,5 po] (taille commerciale)
Taille réelle du trou : 22 mm [0,875 po]

- | | | |
|---|--|--|
| <p>4. Confirm that the electrical terminals used to attach this device are identified for these conductors.</p> <p>5. Twist conductors 1/2 turn or more for every 12 inches of length.</p> <p>6. Keep conductor length as short as possible with no sharp bends.</p> <p>7. Do not loop or coil wires.</p> <p>8. Ensure a high quality ground is in place.</p> <p>9. Install cover and/or close door on equipment.</p> | <p>4. Asegúrese de que las terminales eléctricas utilizadas para conectar este dispositivo hayan sido identificadas para estos conductores.</p> <p>5. Tuerza los conductores vuelta o más por cada 305 mm (12 pulgadas) de longitud.</p> <p>6. Mantenga la longitud de los conductores lo más corta posible evitando doblarlos en ángulo recto.</p> <p>7. No haga bucles o enrolle los cables.</p> <p>8. Asegúrese de que exista una conexión a tierra de alta calidad.</p> <p>9. Instale la cubierta y/o cierre la puerta del equipo.</p> | <p>4. S'assurer que les bornes électriques utilisées pour brancher cet appareil sont identifiées pour ces conducteurs.</p> <p>5. Torsader les conducteurs de 1/2 tour ou plus par 305 mm (12 po) de longueur.</p> <p>6. Maintenir la longueur des conducteurs aussi courte que possible et sans courbures accentuées.</p> <p>7. Ne pas faire de boucles et ne pas enrouler les fils.</p> <p>8. S'assurer qu'une mise à la terre de haute qualité est en place.</p> <p>9. Installer le couvercle et/ou fermer la porte de l'appareil.</p> |
|---|--|--|

Diagnostic Operation

- LED ON = Normal operation
- LED OFF (one or more) = Fault, check phase voltage, circuit breaker (if used) and connections. If OK, replace unit. See Figure 3.

Diagnóstico del funcionamiento del equipo

- LED ENCENDIDO = funcionamiento normal
- LED APAGADO (uno o más) = falla, revise la tensión de fase, los interruptores automáticos (si se utilizan) y las conexiones. Si se muestra OK, vuelva a colocar la unidad. Vea la figura 3.

Fonctionnement du diagnostic

- DÉL ALLUMÉE = Fonctionnement normal
- DÉL ÉTEINTE(S) (une ou plusieurs) = Défaut, vérifiez la tension de phase, les disjoncteurs (si utilisés) et les raccordements. Si tout est normal, remplacer l'appareil. Voir la figure 3.

FIG. 3 : Diagnostic Operation / Diagnóstico del funcionamiento del equipo / Fonctionnement du diagnostic

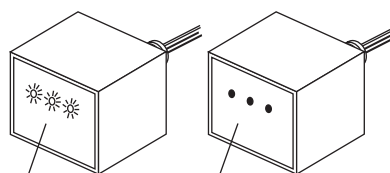

ON = OK / ENCENDIDO = En buen estado / ALLUMÉE = OK

OFF = Fault / APAGADO = Falla / ÉTEINTE = Défaut

General Specifications

Especificaciones generales

Spécifications générales

Product Catalog No. No. de catálogo del producto N° de catalogue de produit	SDSA3650 SDSA3650 SDSA3650
Max Surge Current Corriente transitoria máx. Courant max. de surtension	40 kA/Phase 40 kA/fase 40 kA/phase
Label Rating and Housing Dimensions Etiqueta de clasificación y dimensiones de la caja Étiquette de classification et dimensions du boîtier	Type 4X, see Figure 4 Tipo 4X, vea la figura 4 Type 4X, voir la figure 4
SCCR Rating Corriente nominal de cortocircuito Courant nominal de court-circuit	200 kA 200 kA 200 kA
Product Weight Peso del producto Poids du produit	1 lb 0,45 kg (1 lb) 0,45 kg (1 lb)
Connection Method Método de conexión Méthode de raccordement	Parallel, #12 AWG Wire Paralelo, conductor sólido de 3,31 mm ² (12 AWG) En parallèle, fil rigide de calibre 12 AWG
Thermal Fusing Fusión térmica Fusibles thermiques	Yes Sí Oui
Operating Temperature Temp. de funcionamiento Tempér. de fonctionn.	-40° to +160°F (-40° to +70°C) -40° a +160°F (-40° to +70°C) -40° à +160°F (-40° à +70°C)
Operating Frequency Frecuencia de funcionamiento Fréquence de fonctionnement	50/60 Hz 50/60 Hz 50/60 Hz
Diagnostics Diagnóstico Diagnostics	Green Status LEDs LED de estado, verde DÉL d'état verte
Product Standards Normas del producto Normes du produit	UL 1449-2nd Edition 2005, cUL, ANSI/IEEE C62.11 - C22.2 No. 233.1-87 UL 1449-2nd Ed, 2005, cUL, ANSI/IEEE C62.11 - C22.2 No. 233.1-87 UL 1449-2nd Ed, 2005, cUL, ANSI/IEEE C62.11 - C22.2 No. 233.1-87
	Surge Arrester/TVSS Apartarrayos/ TVSS (supresor de sobretensiones transitorias) Suppresseur de surtensions/SST (suppresseur de surtensions transitoires)

FIG. 4 : Dimensions / Dimensiones / Dimensions



Dim. : in. / pulg / po [mm]

Electrical equipment should be installed, operated, serviced, and maintained only by qualified personnel. No responsibility is assumed by Schneider Electric for any consequences arising out of the use of this material.

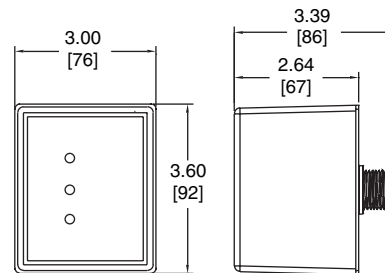
Solamente el personal especializado deberá instalar, hacer funcionar y prestar servicios de mantenimiento al equipo eléctrico. Schneider Electric no asume responsabilidad alguna por las consecuencias emergentes de la utilización de este material.

Seul un personnel qualifié doit effectuer l'installation, l'utilisation, l'entretien et la maintenance du matériel électrique. Schneider Electric n'assume aucune responsabilité des conséquences éventuelles découlant de l'utilisation de cette documentation.

Schneider Electric USA
 8001 Hwy 64 East
 Knightdale, NC 27545 USA
 1-888-SquareD (1-888-778-2733)
 www.us.SquareD.com

Importado en México por:
Schneider Electric México, S.A. de C.V.
 Calz. J. Rojo Gómez 1121-A
 Col. Gpe. del Moral 09300 México, D.F.
 Tel. 55-5804-5000
 www.schneider-electric.com.mx

Schneider Electric Canada
 19 Waterman Avenue, M4B 1 Y2
 Toronto, Ontario
 1-800-565-6699
 www.schneider-electric.ca

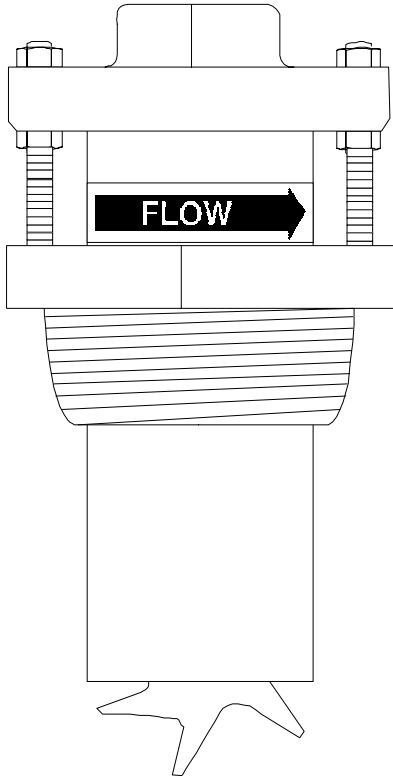

200 Series

Insert Style Flow Sensors

by Data Industrial

Owner's Manual

Introduction

Used in conjunction with any Data Industrial flow monitor or transmitter, Data Industrial non-magnetic flow sensors provide an accurate reading of the rate of liquid flow as well as total accumulated flow. A number of sensor models are offered, which cover applications for a wide range of pipe sizes and pressure/temperature specifications.

The flow sensors generate a frequency which is proportional to flow rate. An internal preamplifier allows the pulse signal to travel up to 2000 feet without further amplification. Power to operate the sensor is provided by the flow monitor. The impeller, shaft, O-rings, and impeller bearings are replaceable in the field.

Data Industrial flow sensors feature a closed, six-bladed impeller design, using a proprietary, non-magnetic sensing technology. The forward-swept impeller shape provides higher, more constant torque than four-bladed impeller designs, and is less prone to fouling by water-borne debris. The forward-curved shape, coupled with the absence of magnetic drag, provides improved operation and repeatability, even at lower flow rates. As the liquid flow turns the impeller, a low impedance 8 VDC signal is transmitted with a frequency proportional to the flow rate.

Sensors of similar type are interchangeable, so there is no need for recalibration after servicing or replacement.

Electronic Types

Data Industrial provides several basic sensor configurations using the same impeller element. This allows for a wide range of applications and pipe sizes. Sensors are normally supplied with 20 feet of Belden Type 9320 (two conductor shielded) cable. Optional sensors designated with the prefix "IR" feature two single conductor 18 AWG stranded copper wire leads 48 inches in length with U.L. Style 1056 direct burial insulation. These IR models are used in below grade applications such as irrigation, municipal, and groundwater monitoring. All 200 series sensor electrical components are self-contained. Pressure/temperature ratings for the various models are contained in the *Specifications* section of this manual. These models can be further described as follows:

"Standard" Sensor

Designed for indoor or protected area applications such as HVAC, pump control, and industrial process monitoring where the flow rates are between 0.5-30 feet/second and temperatures are below 221°F. Standard sensors are supplied with 20 feet of Belden Type 9320 (two conductor shielded) cable.

"IR" Sensor

Designed for below grade applications such as irrigation, municipal, and groundwater monitoring where the flow rates are between 0.5-30 feet/second and temperatures are below 221°F. IR sensors are supplied with two single conductor, 18 AWG stranded copper wire leads 48 inches in length with U.L. Style 1056 direct burial insulation.

"High Temperature" Sensor

Designed for indoor or protected area applications such as hydronic heating loops, boiler feed, and condensate return line monitoring where the flow rates are between 0.5-30 feet/second and temperatures may be up to 285°F. High Temperature 228 and 250 sensors are supplied with 12 inches of Belden Type 9320 (two conductor shielded) cable inside the electronics housing.

"FM/CSA" Sensor

Designed for indoor or protected area applications where intrinsic safety is required and the flow rates are between 0.5-30 feet/second and temperatures are below 221°F. FM/CSA sensors are supplied with 20 feet of Belden Type 9320 (two conductor shielded) cable. These sensors must be used with an approved safety barrier.

"Magnetic" Sensor

Designed for use with the Series 1400 battery powered flow monitor in above or below or grade applications such as irrigation, municipal, and groundwater monitoring where the flow rates are between 1-30 feet/second and temperatures are below 221°F.

Models 220BR, 220PVS, 225BR, 226BR, 220SS and 226SS

Model 220BR

This Insert style sensor has a 5 1/4" long sleeve length, and uses brass and bronze hardware. It is used in all pipe sizes from 2.5" to 40.0" in diameter. A bronze 2" NPT externally threaded hex adapter is provided. The adapter may be mounted to the pipe using a welded-on threaded fitting such as a Thredolet® or pipe saddle.

Model 220PVS

This insert style sensor has an 8" long sleeve length, and uses PVC and stainless steel hardware. It is used in all pipe sizes from 2.5" to 40.0" in diameter. A PVC 2" NPT externally threaded hex adapter is provided. The adapter may be mounted to the pipe using a pipe saddle.

Model 220SS

This is the same as Model 220BR, except that the sensor, sleeve and hex adapter are made of 300 Series stainless steel.

Models 225BR

This insert style sensor has a 16 3/8" long sleeve length, and uses brass and bronze hardware for hot tap installations. It has a bronze isolation gate valve for applications where the pipe is drained for initial installation but cannot be drained for service.

Models 226BR

This is the same as Model 225BR, except that it has a ball type isolation valve. The ball valve allows for higher pressure use. We recommend this sensor when installation is to be made under pressure, in a true "hot tap" installation. The ball valve cannot be fouled by the tailings from the cutting operation.

Models 226SS, IR226SS

This is the same as Model 226BR respectively, except that the hot tap hardware, ball valve, and sensor sleeve are made of 300 Series stainless steel.

Model HTT

This is the insertion tool for use with any of the Hot Tap Sensor units. It is used to insert and remove the sensor while under pressure. Generally, only one HTT tool is needed on each job site.

200 Series Insert Style Matrix (sizes 2½" and up)

Example: 2		x	x	x	x	x	-	x	x	x	x	x
STYLE												
Short Insert												20
Hot Tap Insert-Gate Valve												25
Hot Tap Insert-Ball Valve												26
MATERIAL												
Brass												BR
Stainless Steel												SS
PVC Sleeve w/Stainless Steel Trim												PVS
Size												
Insert Style												00
Electronics Housing												
PPS												0
ELECTRONICS												
Standard												0
IR-Irrigation												1
Magnetic												2
FM/CSA Approved												4
High Temperature												8
O-RING												
Viton												0
EPDM												1
Kalrez												2
Food Grade Silicon												3
Neoprene												4
Chemraz												5
Teflon Encapsulated Viton												6
Teflon Encapsulated Silicone												7
Buna N												8
SHAFT												
Zirconia Ceramic												0
Hastalloy C												1
Tungsten Carbide												2
Titanium												3
Monel												5
316 Stainless Steel												6
Tantalum												7
Hipped Zirconia Ceramic												8
IMPELLER												
Nylon												1
Tefzel												2
BEARING												
Pennlon												1
Tefzel												2
Teflon												3

Mechanical Installation

General

The accuracy of flow measurement for all flow measuring devices is highly dependent on proper location of the sensor in the piping system. Irregular flow velocity profiles caused by valves, fittings, pipe bends, etc. can lead to inaccurate overall flow rate indications even though local flow velocity measurement may be accurate. A sensor located in the pipe where it can be affected by air bubbles, floating debris, or sediment may not achieve full accuracy and could be damaged. Data Industrial flow sensors are designed to operate reliably under adverse conditions, but the following recommendations should be followed to ensure maximum system accuracy:

- 1) Choose a location along the pipe where 10 pipe diameters upstream and 5 pipe diameters downstream of the sensor provide no flow disturbance. Pipe bends, valves, other fittings, pipe enlargements and reductions should not be present in this length of pipe.
- 2) The preferred location around the circumference of a horizontal pipe is on top. If trapped air or debris will interfere, then the sensor should be located further around the pipe from the top but not more than 45 degrees from top dead center. The sensor should never be located at the bottom of the pipe, as sediment may collect there. Locations off top dead center cause the impeller friction to increase, which may affect performance at low flow rates. Any circumferential location is correct for installation in vertical pipes.
- 3) An insertion depth of 1 1/2" for pipe sizes 2.5" and larger is required for accurate flow rate calibration. Detailed installation instructions for various sensor mounting configurations on the following pages include methods for ensuring correct insertion depth.
- 4) Alignment of the sensor to ensure that impeller rotation is parallel to flow is important. Alignment instructions are also included on the following pages.

Installation for 220BR, 220SS

Installation Procedure

The insertion depth and alignment of the sensor assembly are critical to the accuracy of the flow measurement. The Flat End of the sensor tube assembly **MUST BE INSTALLED** 1-1/2" from the inside wall of the pipe. In order to allow for variations in wall thickness, lining or coatings, the depth adjustment is controlled by the position of the Hex Nuts on the three (3) threaded studs of the Hex Mounting Adapter. The Hex Mounting Adapter is provided with a 2" Male NPT connection.

There are two methods of mounting these Data Industrial sensors in a 2.5" or larger pipe. One is with a 2" NPT threaded pipe saddle. The other is with a welded-on fitting such as a Thredolet®, also tapped for a 2" NPT connection. In either case, cut a 2" hole through a depressurized pipe and then secure the saddle or weld-on fitting to the pipe. (For drilling into a pressurized pipe, see instructions for 225 and 226 sensors.) Install the 2" NPT adapter provided, using a thread sealant to prevent leakage. Tighten as necessary. Data Industrial insert style sensors are calibrated with the sensor inserted 1 1/2" into the pipe flow.

To determine the proper insertion depth, proceed as follows:

- 1) **Apply Anti-Seize thread lubricant , supplied with the sensor, to the threaded studs of the mounting adaptor.**
- 2) Determine the height to the upper adjusting nuts on the three 1/4" studs using the insertion depth gauge contained in the 120IK Installation Kit. Set them at 3 3/4" above the inside wall of the pipe.

Note: For 220PVS: Set nuts 6.5" above inside wall of pipe

Figure 1
Installation for 220BR and 220SS

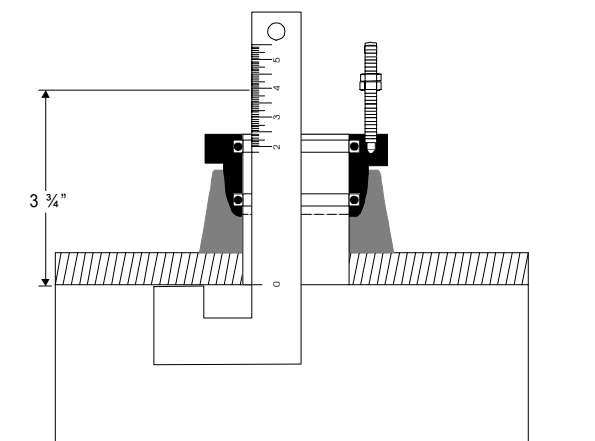

Data Industrial Insert Style Flow Sensors Manual

- 3) Clean O-Rings and flow sensor sleeve, and lightly lubricate O-Rings with silicone grease from the packet provided or some other acceptable lubricant. Take care not to get grease on the impeller or bearing.
- 4) Insert the flow sensor into the 2" NPT adapter so that the mounting holes in the positioning collar fit over the studs on the adapter. Lower the sensor onto the previously adjusted nuts. Install the lock nuts on top of the positioning collar and tighten. Now tighten the lower jam nuts firmly against the upper adjusting nuts to secure them for future removal of the sensor for inspection or service.

Alignment of Flow Sensor

- 1) Loosen positioning collar set screws with a 3/32" Allen wrench. Place the alignment rod through the sight holes in the flow sensor. Refer to Figure 2. Using the alignment rod as a guide, align the flow sensor so that the flow label arrow matches pipe flow direction and so that the alignment rod is exactly parallel to the pipe. This procedure aligns the impeller directly into the fluid flow.

Figure 2
Alignment of Flow Sensor in 220BR and 220SS

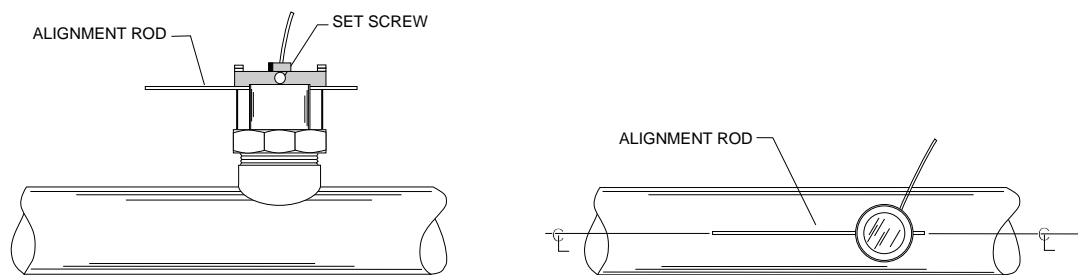

- 2) As a backup to the flow arrow label, there is a small hole next to the larger sighting hole of the upstream side. With a 3/32" Allen wrench, tighten positioning collar set screws.
- 3) Double check that the sighting holes in the sleeve are parallel down the pipe and that the flow arrow label matches pipe liquid flow direction.
- 4) Cable routing: The positioning collar is threaded for connection of a standard 1/2" electrical conduit (flex cable) or a wire strain relief. Route cable as required. Be sure to leave enough flex in cable or conduit to allow future removal of sensor for service or cleaning if necessary.

Hot Tap Installation for 225BR, 226BR, and 226SS

Data Industrial Series 200 Hot Tap style liquid flow sensors are designed for use in cases where pipelines will be in continuous service and depressurizing or draining the system for installation or service is not practical.

The Series 200 Hot Tap sensors are designed to be installed either in a depressurized pipe by hand or "Hot Tapped" into a pressurized pipeline. Both installation procedures are listed in this Application Note. If there is the slightest possibility that the pipe could be full or pressurized, **FOLLOW THE INSTALLATION FOR PRESSURIZED PIPE.**

Refer to Figure 3 for location or identification of the various parts described in the following procedures.

The insertion depth and alignment of the sensor assembly are critical to the accuracy of the flow measurement. The Flat End of the sensor tube assembly **MUST BE INSTALLED 1-1/2"** from the inside wall of the pipe. In order to allow for variations in wall thickness, lining or coatings, the depth adjustment is controlled by the position of the Hex Nuts on the three (3) threaded studs of the Hex Mounting Adapter. The Hex Mounting Adapter is provided with a 2" Male NPT connection. Both Gate and Ball Valve units are provided with 2" nipples for mounting onto saddles, weld-o-lets, etc.

Depth setting is accomplished by positioning the hex nuts 14-7/8" minus the thickness of the pipe, from the Outside Diameter of the Pipe. For example, measure the wall thickness of the pipe from the coupon removed when the 1-7/8" hole was cut into the pipe. If the pipe was 1/8" thick, subtract 1/8" from 14-7/8" or position the nuts 14-3/4" from the outside diameter of the pipe. This will allow the 16-3/8" sensor to protrude 1-1/2" into the pipe.

Apply Anti-Seize thread lubricant, supplied with the sensor, to the threaded studs of the mounting adaptor.

The alignment of the impeller with the flow in the pipe is accomplished by aligning the two (2) "sight holes" at the top of the sensor tube assembly with the center line of the pipe.

Make sure the alignment is made to the pipe and not to a wall or surface near the sensor. To adjust, loosen the two (2) set screws in the positioning collar with a 3/32" Allen wrench provided in the Series 200 Hot Tap Installation Kit. Slip one end of the 1/4" x 18" steel rod (also supplied in the installation kit) through the holes in the sensor tube. Rotate the sensor tube until the rod is centered on the pipe. Ensure the flow label "Arrow" on the sensor matches the liquid flow direction. Tighten the positioning collar Allen Screws to lock the sensor tube assembly in position. Note: As a backup to the flow direction arrow label on the tube assembly, there is a smaller hole located beside one of the sighting holes in the tube, to also indicate the upstream side of the tube assembly.

If the pipe is depressurized and drained

- 1) Drill or cut a 1-7/8" hole in the pipe with a drill or hole saw. Note the pipe wall thickness for use in calculating sensor assembly depth. A location on the top of the pipe is best for overall performance and service life; however, any radial location on the top half of the pipe is acceptable. Allow a minimum of ten (10) pipe diameters upstream and five (5) downstream from the sensor of straight unobstructed pipe to allow full development of the flow profile.
- 2) Install either a service saddle or welded pipe fitting (2" female NPT) on the outside diameter of the pipe over the 1-7/8" hole.
- 3) Install the Data Industrial isolation valve and nipple onto the fitting using pipe thread sealant or teflon tape on all threads.
- 4) Install the Data Industrial Hex Mounting Adapter onto the valve assembly. Use pipe thread sealant on the adapter. Tighten the Hex Adapter so that no stud is aligned with the center-line of the pipe. This could interfere with final sensor alignment. Measure depth and set the height of the nuts of the hex mounting adapter.
- 5) Open the bleed petcock valve on the Hex Adapter to relieve the pressure as the sensor tube is installed. Carefully hand insert the Data Industrial Hot Tap flow sensor tube into the Hex Mounting Adapter. The sleeve should be inserted past the top two "O"-rings in the adapter (approx. 1 - 1-1/4 inches). **Take care not to push the tube in too far as the impeller could be damaged if it strikes the closed valve.**
- 6) Even if the sensor is installed with system drained, Data Industrial recommends that a HTT, Hot Tap Insertion/Removal Tool be purchased for future service. This tool allows the sensor tube assembly to be removed from the pipe line without draining the entire loop where the sensor is mounted.
- 7) In a fully depressurized and drained pipe, the sensor tube assembly may be installed by hand. **Carefully and very slowly** open the isolation valve to relieve any pressure that may have built up. Fully open the isolation valve. Push the sensor tube into the pipe with a slight twisting motion. Guide the sensor collar holes over the three hex adapter studs until the collar rests on the nuts. Hex nuts should have been previously set to the correct height. Install the three (3) lock nuts onto these studs at the top of the positioning collar and securely tighten.

- 8) Loosen the two set screws in the positioning collar with a 3/32" Allen wrench. Align the sensor sight holes along the pipe axis using the alignment rod provided in the installation kit supplied with the sensor. Ensure that the flow label arrow on the sensor matches the liquid flow direction inside the pipe. Tighten the positioning collar set screws. Note: As a backup to the flow label arrow, there is a small hole located beside one of the sighting holes to also indicate the upstream side of the sensor.

Installation into a pressurized pipeline using Model HTT.

For information on installing hot tap sensor with older 225H consult technical bulletin #41

For pipe sizes 2½" and above; all Data Industrial sensors are inserted 1 1/2" from the inside wall of the pipe. The insertion depth is controlled by the position of the hex nuts on the three threaded rods. The formula below defines the distance between the top of the sensor hex mounting adaptor and the bottom of the positioning collar (the top of the hex nut). Reference Figure 3.

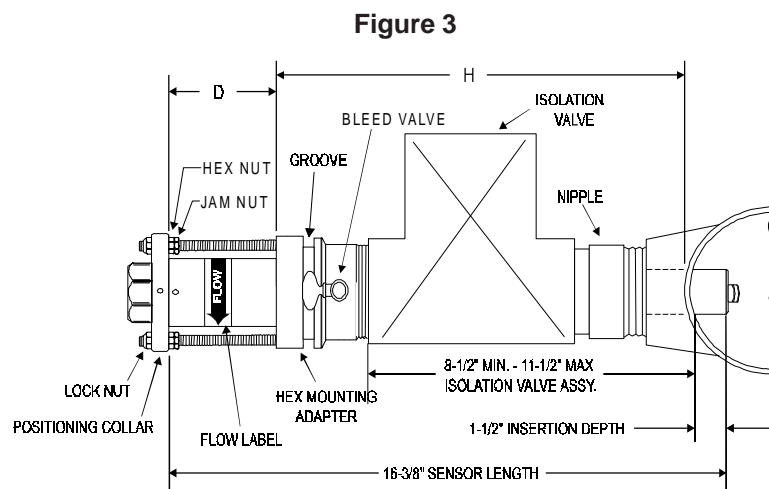

$$D = 16 \frac{3}{8} - (H + \text{Pipe Wall Thickness} + 1.5 \text{ " })$$

Example: If sensor is installed in a 8"Sch 80 pipe with a pipe wall thickness of .5" and the "H" dimension is 10" then the calculation would be as below:

$$D = 16 \frac{3}{8} - (10 \text{ " } + 0.5 \text{ " } + 1.5 \text{ " })$$

$$D = 4 \frac{3}{8} \text{ " }$$

1. Set one set of hex/jam nuts so that the distance between the top surface of the hex nut and the top surface of the Hex Mounting Adaptor is equal to the "D" dimension calculated above. Then adjust the other two sets of hex/jam nuts 1½" below the first jam nut to allow clearance for the tool top yoke.
2. Remove the tool split ring and clevis pin and slide tool bottom yoke into the groove on the sensor Hex Mounting Adaptor and secure by replacing the clevis pin and split ring.
3. Mark sleeve 2¾" from impeller end of metal sleeve. This mark is a stopping point to insure that impeller/bearing is not damaged. Open the bleed petcock valve on the Hex Adapter to relieve the pressure resulting from the sensor tube insertion. Carefully hand insert the Data Industrial Hot Tap flow sensor sleeve assembly into the Hex Mounting Adapter until the mark lines up with the top of the Hex Mounting Adapter. At this point the sleeve will have been inserted past the top two "O"-rings in the adapter (approx. 1 - 1-1/4 inches). Take care not to push the sensor past the mark on the sleeve as the impeller could be damaged if it strikes the closed valve.
4. Fully extend tool by turning drive nut counterclockwise with a 15/16" socket or box wrench (not provided) until drive nut contacts tool and slide the positioning collar into the tool top yoke.
5. Rotate tool so the threaded rod with the adjusted hex/jam nuts is centered in the top yoke of hot tap tool.
6. Rotate sensor sleeve so positioning collar holes align with the threaded rods and flow direction label is in general direction making sure the positioning collar is located in the recessed area of the top yoke. Slide the top yoke of the tool over the positioning collar and secure by tightening the two thumbscrews on the top of the yoke.

7. Close the bleed petcock and slowly open the isolation valve. Slowly turn the 15/16" drive nut clockwise to insert the sensor tube assembly through the valve and into the pipeline. Carefully guide the three (3) threaded studs of the Hex Mounting Adapter through the holes of the sensor positioning collar. Carefully lower the sensor until the Positioning collar contacts the hex nut preset for the correct depth adjustment. Install the three (3) lock nuts onto the threaded rods, tightening only the lock nut on the threaded rod with the preset hex/jam nut; then, bring the two remaining lock nuts down until they just contact the positioning collar. Do not tighten at this time
8. Remove the Model HTT Insertion/Removal Tool, by loosening the two thumbscrews, removing the clevis pin and then sliding the insertion tool off the sensor. Then bring the two remaining sets of hex/jam nuts up to the underside of the positioning collar, and tighten.
9. Align the sensor by first loosening the two set screws in the side of positioning collar with a 3/32" Allen wrench, Then align the sensor sight holes along the pipe axis using the alignment rod provided in the sensor installation kit. Ensure that the flow label arrow on the sensor matches the liquid flow direction inside the pipe. Tighten the positioning collar set screws. Note: As a backup to the flow label arrow, there is a small hole located beside the sight hole on the upstream side of the sensor.

Electrical Installation "Standard" sensors

- 1) The metal collar on the top of the 220 sensors will accept 1/2" threaded conduit fittings.
- 2) Route the cable from the sensor to a Data Industrial flow monitor/transmitter. The cable may be extended up to 2000 feet, using 2-conductor shielded 20 AWG or larger stranded copper wire. Be sure to leave enough flexibility in the cable or conduit to allow for future service of sensor, if necessary.
- 3) When connecting to a Data Industrial flow monitor/transmitter, locate the section of terminal strip on the monitor labeled "**SENSOR INPUT**" or "**SENSOR**". Connect the red wire to "**IN**", "**SIGNAL(+)**" or "**SIGNAL**" terminal and the black wire to "**GND**", "**SIGNAL(-)**", or "**COM**" terminal and the shield drain wire (if applicable) to "**SLD**".
- 4) When interfacing with other equipment consult manufacture for input designations. The signal wave forms and power requirements are as shown in the Specifications section.

Electrical Installation "IR" sensors

The sensor leads are supplied with watertight caps over the ends.

- 1) **DO NOT** remove the plastic caps from the sensor leads until ready to splice.
- 2) Use a **twisted pair** cable suitable for direct burial to connect the sensor to the transmitter, monitor, or controller. Multi-pair telecommunication cable or direct burial cables may be used.
- 3) Make a water tight splice. Two part epoxy type waterproof kits are recommended. Be sure the epoxy seals the ends of the cable jacket.
- 4) Make sure the epoxy is hardened before inverting the splice or dropping it in standing water.
- 5) **DO NOT** make an underground splice unless absolutely necessary.
- 6) Route the cable from the sensor to a Data Industrial flow monitor/transmitter. The cable may be extended up to 2000 feet, using 2-conductor shielded 20 AWG or larger stranded copper wire. Be sure to leave enough flexibility in the cable or conduit to allow for future service of sensor, if necessary.
- 7) When connecting to a Data Industrial flow monitor/transmitter, locate the section of terminal strip on the monitor labeled "**SENSOR INPUT**" or "**SENSOR**". Connect the red wire to "**IN**", "**SIGNAL(+)**" or "**SIGNAL**" terminal and the black wire to "**GND**", "**SIGNAL(-)**", or "**COM**" terminal and the shield drain wire (if applicable) to "**SLD**".
- 8) When interfacing with other equipment, the signal wave forms and power requirements are as shown in the Specifications section.

Data Industrial Insert Style Flow Sensors Manual

Electrical Installation "High Temperature" sensors

- 1) Route a cable from the sensor to a Data Industrial flow monitor/transmitter. The cable may be run up to 2000 feet, using 2-conductor shielded 20 AWG or larger stranded copper wire. Be sure to leave enough flexibility in the cable or conduit to allow for future service of sensor, if necessary.
- 2) Connect to cable inside sensor electronic housing on 220 Series sensors or attach to the sensor cable on the 225/226 Series and connect with standard wire nuts.
- 3) When connecting to a Data Industrial flow monitor or transmitter, locate the section of terminal strip on the monitor labeled "**SENSOR INPUT**" or "**SENSOR**". Connect the red wire to "**IN**", "**SIGNAL(+)**" or "**SIGNAL**" terminal and the black wire to "**GND**", "**SIGNAL(-)**", or "**COM**" terminal and the shield drain wire (if applicable) to "**SLD**".
- 4) When interfacing with other equipment, the signal wave forms and power requirements are as shown in the Specifications section.

Electrical Installation "Magnetic" sensors

The magnetic sensor has a custom wire connector that connects to the series 1400 monitor only. The cable may be extended up to 100 feet from the sensor. If extension cables are needed they may be ordered from Data Industrial.

Electrical Installation (FM Sensors)

The Series 200 Sensor is approved, as an entity, as Intrinsically Safe when installed in conformance with Data Industrial installation drawings 06-480-001 or 06-480-002 (samples shown on Page 6) as specified on the blue label identifying an intrinsically safe sensor.

Entity approval implies that only the sensor is approved as intrinsically safe. Unless power supplies, equipment, and instruments connected to the sensor are each rated either explosion-proof or intrinsically safe, these devices cannot be installed in a hazardous area. The referenced installation drawing shows such apparatus located in a non-hazardous location. Proper interfacing between the hazardous and non-hazardous areas must be provided. It is of absolute importance that this interface be constructed and that all wiring be performed by qualified contractors. To ensure the Intrinsic Safety of the installation, the connection of the intrinsically safe sensor to instruments and or power supplies must take place using an approved intrinsically safe barrier located in a non-hazardous area. These barriers, listed below, are readily available from various suppliers.

Manufacturer:
Crouse-Hinds Spec 504
Measurement Technology Ltd.
R Stahl Intrinsicpak

Barrier:
Cat No. SB19140M0715
MTL 715+ 15 V
9001/01-158-150-10

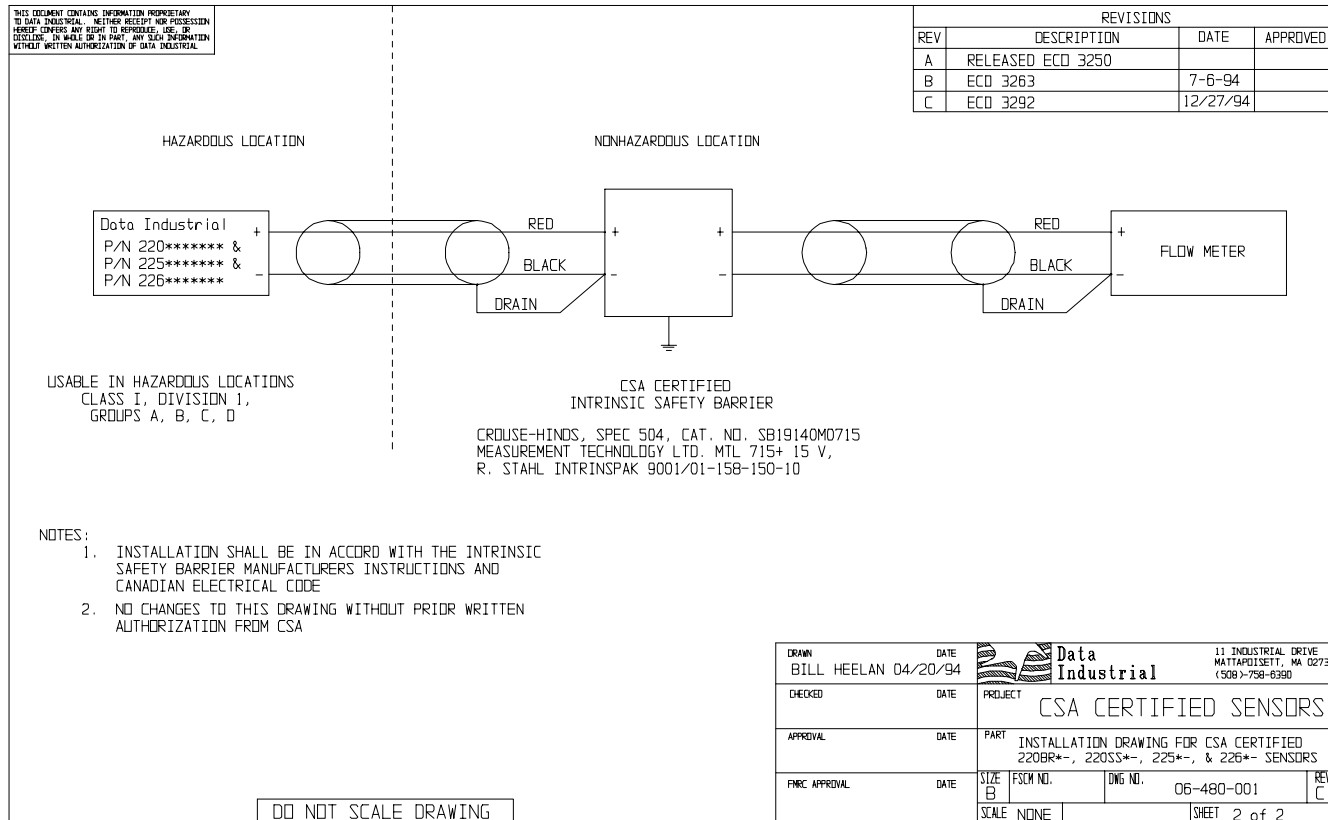
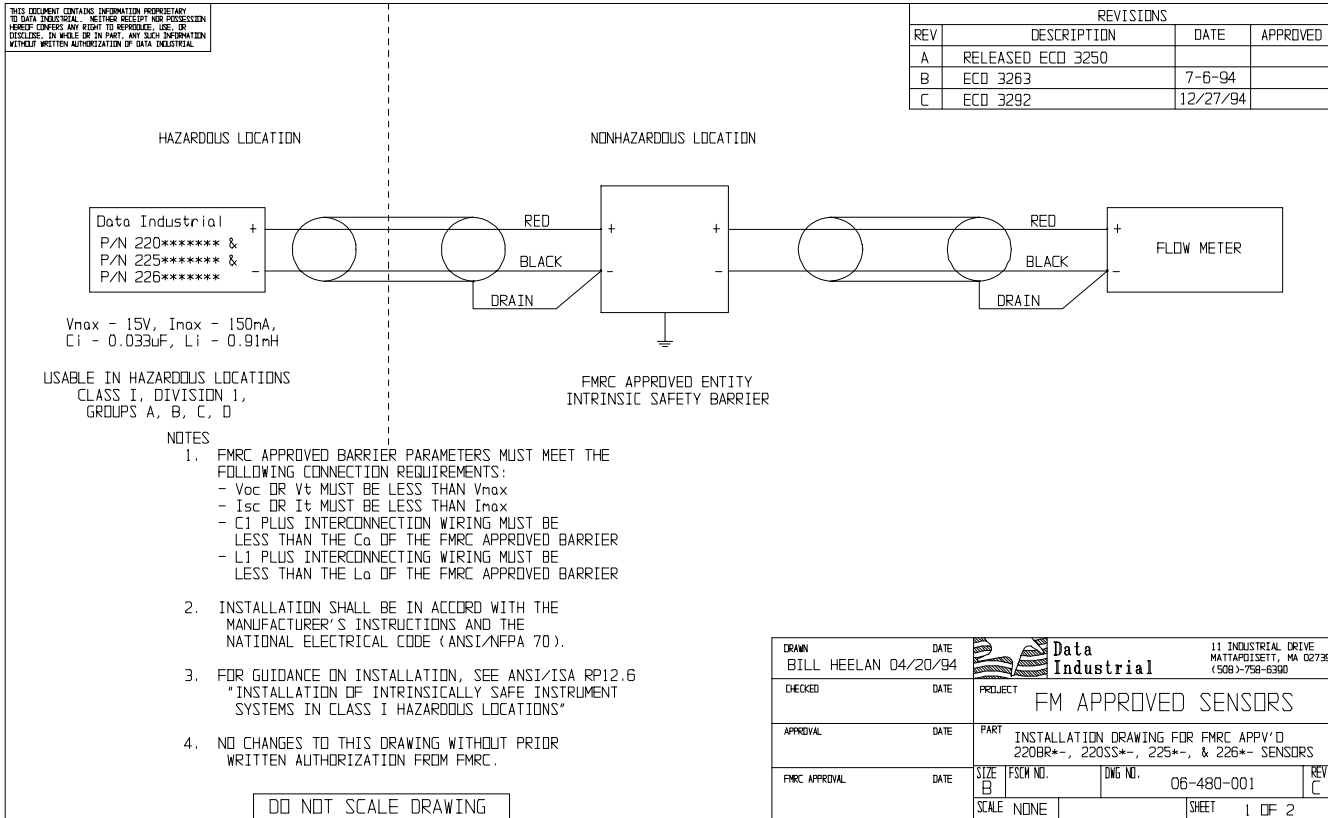

Calibration

Data Industrial sensors use unique K and offset numbers for calibration. These numbers are derived from calibration runs using NIST traceable instruments. Using both a K and an offset number provides higher accuracy than using a K factor alone. K and offset numbers for each tee configuration are listed in the following tables.

Calibration Tables

The table on pages 11 and 12 provides calibration and operation data for most scheduled pipe sizes from 3" through 18". For tee-mounted sensors, see the table on page 11.

Description of Column Information for Pipe Sizes 3" through 36"

Column 1	Nominal Pipe Size
Column 2	Pipe O.D. as defined by ASA B36.10 and other standards
Column 3	Pipe I.D. as defined by ASA B36.10 and other standards
Columns 4 and 5	The K value and Offset that should be used in our frequency equation:

$$\text{Freq} = \frac{\text{Gpm}}{K} - \text{offset}$$

This equation describes the frequency of the output signal of all Data Industrial flow sensors. By substituting the appropriate K and Offset values from the table, the sensor's output frequency can be calculated for each pipe size. This information is required when calibrating an output board or when using the raw sensor data as direct output to interface with a device that is not a Data Industrial product.

Column 6	<p>This column indicates the suggested flow range of sensors in each pipe size. Data Industrial sensors will operate both above and below the indicated flow rates. However, good design practice dictates the use of this range for best performance.</p> <p>Sensors should be sized for flow rather than pipe size. To prevent disturbances to the flow profile always connect the sensor tee to pipe nipples measuring at least 10 pipe diameters in length on the up stream (supply) side and at least 5 pipe diameters in length on the downstream (delivery) side before making the transition in pipe size.</p>
----------	--

CALIBRATION TABLE FOR PIPE SIZES 3" THROUGH 36"

Column 1	Column 2	Column 3	Column 4	Column 5	Column 6
Pipe Size	Pipe O.D.	Pipe I.D.	K Value	Offset	Suggested Operating Range (GPM)
3" Sch 10S	3.500"	3.260"	5.009	.090	12-400
Std. Wt., Sch 40	3.5"	3.068"	4.362	.063	12-400
Extra Strong, Sch 80	3.5"	2.900"	3.858	.043	12-400
PVC Class 125	3.5"	3.284"	5.094	.093	12-400
PVC Class 160	3.5"	3.230"	4.902	.085	12-400
PVC Class 200	3.5"	3.166"	4.682	.076	12-400
4" Sch 10S	4.5"	4.260"	9.597	.241	20-600
Std. Wt., Sch 40	4.5"	4.026"	8.34	.229	20-600
Extra Strong, Sch 80	4.5"	3.826"	7.354	.188	20-600
PVC Class 125	4.5"	4.224"	9.396	.240	20-600
PVC Class 160	4.5"	4.154"	9.013	.240	20-600
PVC Class 200	4.5"	4.072"	8.578	.239	20-600
5" Sch 10S	5.563"	5.295"	16.305	.250	30-900
Std. Wt., Sch 40	5.50"	5.047"	14.674	.248	30-900
Extra Strong, Sch 80	5.50"	4.813"	13.165	.246	30-900
6" Sch 10S	6.625"	6.357"	24.089	.260	50-1,500
Std. Wt., Sch 40	6.5"	6.065"	21.574	.257	50-1,500
Extra Strong, Sch 80	6.5"	5.761"	19.457	.254	50-1,500
PVC Class 125	6.625"	6.217"	22.853	.258	50-1,500
PVC Class 160	6.625"	6.115"	21.968	.257	50-1,500
PVC Class 200	6.625"	5.993"	21.068	.256	50-1,500
8" Sch 10S	8.625"	8.329"	43.914	0.286	80-2,500
Sch 20	8.625"	8.125"	41.653	0.283	80-2,500
Sch 30	8.625"	8.071"	41.063	0.283	80-2,500
Std. Wt., Sch 40	8.625"	7.981"	40.086	0.281	80-2,500
Sch 60	8.625"	7.813"	38.288	0.279	80-2,500
Extra Strong, Sch 80	8.625"	7.625"	36.315	0.276	80-2,500
PVC Class 125	8.625"	8.095"	41.324	0.283	80-2,500
PVC Class 160	8.625"	7.961"	39.869	0.281	80-2,500
PVC Class 200	8.625"	7.805"	38.203	0.279	80-2,500
10" Sch 10S	10.75"	10.420"	70.195	0.321	125-4,000
Sch 20	10.75"	10.250"	67.668	0.318	125-4,000
Sch 30	10.75"	10.136"	66.069	0.316	125-4,000
Sch 40, Std.Wt.	10.75"	10.020"	64.532	0.314	125-4,000
Extra Strong, Sch 60	10.75"	9.750"	61.016	0.309	125-4,000
Sch 80	10.75"	9.564"	58.644	0.306	125-4,000
PVC Class 125	10.75"	10.088"	65.431	0.315	125-4,000
PVC Class 160	10.75"	9.924"	63.272	0.312	125-4,000
PVC Class 200	10.75"	9.728"	60.733	0.309	125-4,000
12" Sch 10S	12.75"	12.390"	104.636	0.367	175-5,000
Sch 20	12.75"	12.250"	102.553	0.364	175-5,000
Sch 30	12.75"	12.090"	99.347	0.36	175-5,000
Std. Wt., Sch 40S	12.75"	12.000"	97.576	0.358	175-5,000
Sch 40	12.75"	11.938"	97.369	0.356	175-5,000
Sch 60	12.75"	11.625"	90.441	0.348	175-5,000
Extra Strong	12.75"	11.750"	92.775	0.351	175-5,000
Sch 80	12.74"	11.376"	85.922	0.342	175-5,000
PVC Class 125	12.75"	11.966"	96.912	0.357	175-5,000
PVC Class 160	12.75"	11.770"	93.152	0.352	175-5,000
PVC Class 200	12.75"	11.538"	88.842	0.346	175-5,000

Continued on Next Page

CALIBRATION TABLE FOR PIPE SIZES 3" THROUGH 36"

Column 1	Column 2	Column 3	Column 4	Column 5	Column 6
Pipe Size	Pipe O.D.	Pipe I.D.	K Value	Offset	Suggested Operating Range (GPM)
14" Sch 10S	14.00"	13.500"	122.307	0.391	200-6,000
Sch 20	14.00"	13.375"	120.216	0.388	200-6,000
Std. Wt., Sch 30	14.00"	13.250"	118.151	0.385	200-6,000
Sch 40	14.00"	13.124"	116.096	0.382	200-6,000
Sch 60	14.00"	12.814"	111.148	0.376	200-6,000
Extra Strong	14.00"	13.00"	114.098	0.33	200-6,000
Sch 80	14.00"	12.50"	106.299	0.369	200-6,000
16" Sch 10S	16.00"	15.500"	159.243	0.44	300-9,000
Sch 20	16.00"	15.375"	156.742	0.436	300-9,000
Std. Wt., Sch 30	16.00"	15.250"	154.267	0.433	300-9,000
Sch 60	16.00"	14.688"	143.456	0.419	300-9,000
Extra Strong, Sch 40	16.00"	15.000"	149.394	0.427	300-9,000
Sch 80	16.00"	14.314"	136.548	0.41	300-9,000
18" Sch 10S	18.00"	17.500"	202.739	0.498	350-10,000
Sch 20	18.00"	17.375"	199.828	0.494	350-10,000
Sch 30	18.00"	17.124"	194.061	0.486	350-10,000
Std. Wt.	18.00"	17.250"	196.943	0.49	350-10,000
Sch 40	18.00"	16.876"	188.464	0.479	350-10,000
Sch 60	18.00"	16.500"	180.171	0.469	350-10,000
Extra Strong	18.00"	17.000"	191.25	0.482	350-10,000
Sch 80	18.00"	16.126"	172.152	0.457	350-10,000
20" Std. Wt., Sch 20	20.00"	19.25"	246.179	0.555	400-12,000
Sch 40	20.00"	18.812"	234.836	0.540	400-12,000
Extra Strong, Sch 30	20.00"	19.000"	239.666	0.547	400-12,000
Sch 80	20.00"	17.938"	213.14	0.511	400-12,000
22" Std. Wt., Sch 20	22.00"	21.25"	301.975	0.621	500-15,000
Extra Strong, Sch 30	22.00"	21.00"	294.642	0.616	500-15,000
Sch 80	22.00"	19.75"	259.513	0.573	500-15,000
24" Std. Wt., Sch 20	24.00"	23.25"	364.331	0.666	600-18,000
Extra Strong	24.00"	23.00"	356.178	0.660	600-18,000
Sch 40	24.00"	22.624"	344.109	0.652	600-18,000
Sch 80	24.00"	21.562"	311.271	0.628	600-18,000
26" Sch 10	26.00"	25.376"	437.809	0.719	700-21,000
Std. Wt.	26.00"	25.25"	433.247	0.716	700-21,000
Sch 20, Extra Strong	26.00"	25.00"	424.274	0.709	700-21,000
28" Sch 10	28.00"	27.376"	513.698	0.774	900-23,000
Std. Wt.	28.00"	27.25"	508.723	0.770	900-23,000
Extra Strong, Sch 20	28.00"	27.00"	498.930	0.763	900-23,000
30" Sch 10	30.00"	29.376"	596.147	0.833	1,000-30,000
Std. Wt.	30.00"	29.25"	590.759	0.829	1,000-30,000
Sch 20, Extra Strong	30.00"	29.00"	580.146	0.822	1,000-30,000
32" Sch 10	32.00"	31.376"	685.156	0.897	1,200-35,000
Std. Wt.	32.00"	31.25"	679.355	0.893	1,200-35,000
Sch 20, Extra Strong	32.00"	31.00"	667.922	0.885	1,200-35,000
Sch 40	32.00"	30.624"	650.919	0.873	1,200-35,000
34" Sch 10	34.00"	33.312"	777.566	0.964	1,300-40,000
Std. Wt.	34.00"	33.25"	774.511	0.962	1,300-40,000
Extra Strong, Sch 20	34.00"	33.00"	762.258	0.953	1,300-40,000
Sch 40	34.00"	32.624"	744.022	0.940	1,300-40,000
36" Sch 10	36.00"	35.376"	882.855	1.040	1,500-45,000
Std. Wt.	36.00"	35.25"	876.227	1.035	1,500-45,000
Sch 20, Extra Strong	36.00"	35.00"	863.154	1.025	1,500-45,000
Sch 40	36.00"	34.50"	837.315	1.007	1,500-45,000

Impeller Assembly and Shaft Replacement

If you are replacing an existing Data Industrial sensor and have already calibrated your flow monitor/transmitter, no calibration changes are necessary. For installation of a new flow monitor or for relocation of a sensor in a new pipe size, please refer to the calibration instructions in flow monitor manual.

- 1) Depressurize pipe from which sensor is to be removed. If the sensor is one of the 225/IR225 or 226/IR226 series, consult the installation section on Hot Tap Sensors.

NEVER disturb the securing lock nuts with pipe under pressure without hot tap insertion tool Model HTT installed.

- 2) Remove the three (3) lock nuts that secure the positioning collar to the threaded rods of metal sensor.

NOTE: Before removing lock nuts, record the dimension from top of 2" NPT adapter to the bottom of the positioning collar. This dimension will be required later to reinstall.

- 3) Remove the sensor from the hex adapter or the tee.
- 4) Note the impeller blade orientation relative to flow arrows and the alignment hole in metal sensors beside one of the sighting holes. In order to maintain proper calibration, the impeller will have to be reinstalled in the same manner with the impeller blades pointing toward the small alignment hole, and into the flow direction as indicated by the flow arrows.
- 5) To remove the old impeller blade assembly, push the old shaft out of the sleeve with the new shaft (or small diameter rod) just far enough to grab the end with a pair of pliers and pull the shaft completely out. The impeller assembly will now be free, and will drop out.
- 6) Inspect the shaft and bearings for wear, and replace as necessary.
- 7) Refer to Figure 4. To reinstall, position the impeller in the cavity oriented as in Step 4 so that the impeller blades point into the flow direction and toward the small alignment hole located beside one of the sighting holes on metal sensors.
- 8) Carefully push the shaft through the sleeve and impeller, taking care not to damage bearings. Make sure that the shaft is inserted far enough so that it clears the sleeve on each side of the impeller housing.

NOTE: If shaft is not carefully installed, the bearing can be deformed, preventing free rotation.

- 9) Inspect the O-rings for damage and replace as necessary. Clean the O-rings and the sleeve and relubricate with silicone grease from the packet provided or some other acceptable lubricant.
- 10) Install the sensor into the 2" NPT adapter or tee so that alignment hole is facing upstream and flow arrows point in the direction of the actual flow. Since the positioning collar was not loosened during this operation, the studs should all line up perfectly when the sighting holes are parallel to pipe. If this has been accidentally loosened, please refer to the installation instructions for the alignment of the flow sensor unit.
- 11) Install and tighten the nuts.
- 12) For metal sensors, double check that the distance from the top of the 2" NPT adapter to the bottom of the positioning collar equals the dimension as measured in Step 2, and holes in sleeve sight exactly down the pipe, the arrows point in direction of flow and alignment holes located beside one sighting hole is pointing towards the source. If not, refer to *Installation* section in this manual.
- 13) This completes the replacement procedure. The system may now be repressurized and tested.

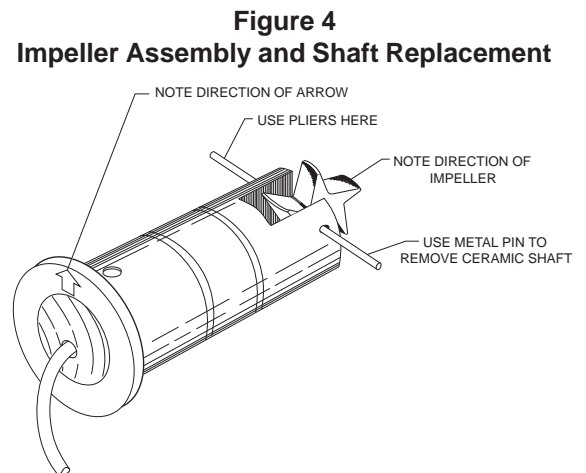

Troubleshooting (all but 24volt and FM/CSA electronics)

- 1) Using a voltmeter on the 0-20 VDC scale, connect the voltmeter across the sensor wires which are connected to the sensor input on the barrier strip. The voltage reading should be 8 VDC \pm 0.5 V with no flow in the pipe. If the reading is in range, go to step 2. If not, go to step 3.
- 2) With the sensor installed in the pipe and flow through the pipe, connect the volt meter across the sensor wires at the sensor input of the barrier strip. The voltage should fall between 4 VDC and 8 VDC. The higher the flow rate, the lower the DC voltage level should drop. It should not drop below 4 VDC as your meter averages the DC level of the square wave signal generated by the sensor.

If this is correct, the flow sensor should be operational, and the flow monitor should display a flow rate or the transmitter output should change with a change in flow at the sensor. The signal generated by the sensor is a square wave with 5 msec pulses up to 100 Hz (at which time the pulses narrow to a 50% duty cycle), the use of an oscilloscope on the 5 msec time base, 2 VDC/division would indicate that the sensor is operating properly.

- 3) If the voltage at the sensor input is less than 7 VDC in a No Flow situation or less than 3 VDC in a flow situation, disconnect the sensor from the barrier strip and measure the voltage at the sensor input terminals of the barrier strip again. It should be between 8 VDC and 12 VDC. If the voltage is between 8-12 VDC, the sensor is bad. If the voltage at the sensor input is still below 7 VDC or 3 VDC, the problem may be with the monitor.
- 4) If you suspect that the sensor is bad, you can test the monitor circuitry by connecting a piece of wire to one of the sensor input terminals and tap the other side of the wire to the other sensor input terminal. Shorting across the sensor input terminals ON and OFF repeatedly allows the display to respond by trying to calculate a flow rate for the frequency of your shorting action. If the display does not show a change from 0.00, it indicates a problem with the monitor.

Troubleshooting 24volt and FM/CSA electronics

- 1) If the voltage at the sensor input is less than 7 VDC in a No Flow situation, disconnect the sensor from the barrier strip and measure the voltage at the sensor input terminals of the barrier strip again. It should be between 8 VDC and 20 VDC. If the voltage at the sensor input is still below 7 VDC or 3 VDC, the problem may be with the monitor.
- 2) If you suspect that the sensor is bad, you can test the monitor circuitry by connecting a piece of wire to one of the sensor input terminals and tap the other side of the wire to the other sensor input terminal. Shorting across the sensor input terminals ON and OFF repeatedly allows the display to respond by trying to calculate a flow rate for the frequency of your shorting action. If the display does not show a change from 0.00, it indicates a problem with the monitor.

Specifications

Wetted Materials for all sensors

- (see ordering matrix)

Sensor Sleeve and Hex Adapter for 220BR, 225BR, and 226BR

- Sleeve: Admiralty Brass, UNS C44300; Hex Adapter: Valve Bronze, UNS C83600

Sensor Sleeve and Hex Adapter for 220SS and 226SS

- 300 Series Stainless Steel

Temperature Ratings

- Standard Version:
 - 221°F (105°C) continuous service
- High Temperature Version:
 - 285°F (140.6°C) continuous service
 - 305°F (150°C) peak temperature (limited duration)

Pressure Ratings

	At 100°F	At 300°F
220SS	400 psi	325 psi
220B	400 psi	325 psi
225B	300 psi	210 psi
226B	400 psi	250 psi
226SS	400 psi	300 psi

Recommended Design Flow Range

- 0.5 to 30 ft/sec
- Initial detection below 0.3 ft/sec

Accuracy

- $\pm 1.0\%$ of full scale over recommended design flow range

Repeatability

- $\pm 0.3\%$ of full scale over recommended design flow range

Linearity

- $\pm 0.2\%$ of full scale over recommended design flow range

Transducer Excitation (Std. electronics)

- Typically provided by Data Industrial flow monitor or transmitter. Any alternate supply must be of a resistance-limited type meeting the following constraints:
 - Source current @ 8 Volts: 1 mA minimum, 20mA maximum
 - Short Circuit Current: 200 mA maximum

Transducer Excitation (FM and 24V electronics)

- Quiescent current 600uA@8VDC to 35VDC max.
- Quiescent voltage (V_{high})
Supply Voltage $-(600uA * \text{Supply impedance})$
- ON State (V_{Low}) Max. 1.2VDC@40mA current limit (15ohm+0.7VDC)

Output Frequency

- 3.2 Hz to 200 Hz

Output Pulse Width

- 5 msec $\pm 25\%$

Electrical Cable for Series 200 Sensors

- 22 feet of Belden shielded 2-conductor stranded copper AWG 20 with AWG 22 drain wire provided for connection to display or analog transmitter unit. Rated to 105°C. May be extended to a maximum of 2000 feet with similar cable and insulation appropriate for application.

Electrical Cable for Series IR200 Sensors

- 48 inches of U.L. Style 1056 copper stranded AWG 18 wire w/direct burial insulation. Rated to 105°C.

Warranty

Data Industrial Corporation ("Seller") of 11 Industrial Drive, Mattapoisett, Massachusetts 02739-0740, U.S.A., warrants to the original purchaser of its product that such product manufactured by Data Industrial Corporation shall be free from defects in materials or workmanship when installed, serviced and operated according to Data Industrial Corporation instructions or in other such normal use. This warranty is effective for a period of 12 months from the date of installation by the Purchaser or 18 months from the date of shipment by the "Seller" whichever occurs or terminates first. This limited warranty does not cover damage or loss resulting from corrosion or erosion caused by acids or other chemicals or by severe environmental conditions or negligent or improper installation or improper operation, misuse, accident, unauthorized repair or substitution of components other than those provided by the "Seller", and does not cover limited life components such as bearings, shafts, impellers where wear rate is a function of application and environment. Any component not manufactured by the "Seller" but included in its products shall not be covered by this warranty and is sold only under such warranty as the manufacturer may provide.

If Buyer or Purchaser wishes to make a claim hereunder, he shall send written notice of any defect within the warranty period, to "Seller" at the above address. "Seller" may at its sole option instruct Buyer to ship subject part, postage prepaid, to the "Seller" at above address or authorize a representative to inspect the part on site. "Seller" will at its sole option repair or replace any defective product covered by this warranty. If Buyer makes repairs or alterations to any product or part covered by this warranty without "Seller's" prior written approval, this warranty shall be null and void.

The foregoing shall constitute Buyers or Purchasers sole and exclusive remedy against "Seller", and no other remedy, including but not limited to, incidental or consequential damages for personal injury, loss of fluids, gases or other substances or for loss of profits or injury to property or person shall be available to the Buyer or Purchaser. The warranty extended herein shall be in lieu of any other implied warranty of merchantability or fitness for a particular purpose, and seller shall bear no liability for representatives or retail sellers. In no event shall Data Industrial Corporation be liable for any contingent, incidental, or consequential damage or expenses due to partial or complete inoperability of its product.

All rights reserved. No part of this work covered by the copyrights hereon may be reproduced or copied in any form or by any means - graphic, electronic, or mechanical, including photocopying, recording, taping, or information and retrieval systems - without written permission of Data Industrial.

Copyright © 1997
Data Industrial Corporation
11 Industrial Drive
Mattapoisett, Ma. 02739
www.dataindus.com
email: techsales@dataindus.com
508-758-6390
FAX: 508-758-4057

Model 310 Loop Powered Analog Output Transmitter Installation Guide

by Data Industrial

Mechanical installation

The Model 310 may be surface mounted onto a panel, attached to DIN rails using adapter clips or wall mounted using two optional enclosures.

Location

Although the Model 310 is encapsulated, all wiring connections are made to exposed terminals. The unit should be protected from weather and moisture in accordance with electrical codes and standard trade practices.

In any mounting arrangement, the primary concerns are ease of wiring and attachment of the programming cable.

The unit generates very little heat so no consideration need be given to cooling or ventilation.

Surface Mount Installation

The Model 310 may be mounted to the surface of any panel using double sided adhesive tape or by attaching fasteners through the holes in the mounting flanges of the unit.

Figure 1: Model 310 Dimensions

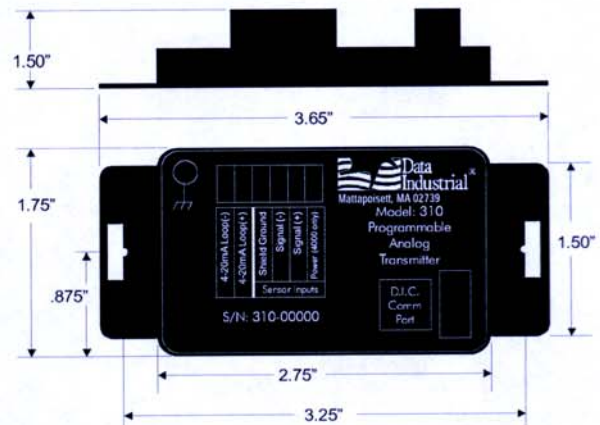
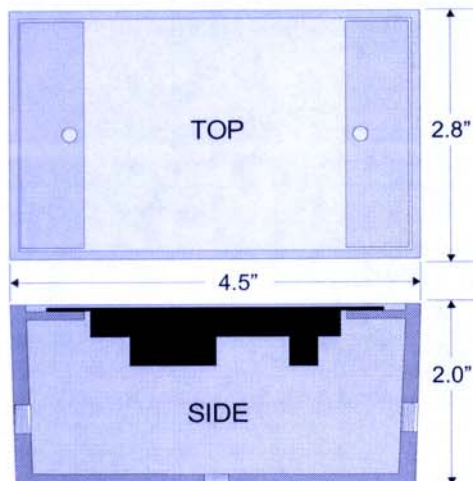

Figure 2: 310 Optional Enclosure Dimensions



DIN Rail Mounting

Optional clips snap onto the mounting flanges allowing the Model 310 to be attached to DIN 15, 32, 35 mm DIN rail systems.

Wall Mounting

Optional metal and plastic enclosures are available to mount the Model 310 to a wall when no other enclosure is used. The enclosure is first attached to the wall using fasteners through its mounting holes.

After wiring, the transmitter may be attached to the enclosure with the terminal headers facing in using the slots in the mounting flanges. As an alternate mounting arrangement, the Model 310 may be fastened to the box cover using double-sided adhesive tape.



PN# 72019
03/20/03

Model 310 Electrical Installation

Per standard wiring practices, the loop power must be off before making any wire connections. The terminal strips have removable plug-in connectors to make wiring easier.

1. Refer to Figure 3 for terminal connections.
2. As shown in figure 4, connect loop power supply positive (+) to Model 310 terminal marked 4-20mA loop (+).
3. Connect terminal marked 4-20mA loop (-) of Model 310 to positive (+) analog terminal of input device (Chart Recorder, PLC, etc.).
4. Connect negative (-) analog terminal of input device to loop power supply negative (-).
5. **If Wiring a Series 200 sensor**, connect the red wire (signal) to Signal (+) terminal, black wire (common) to Signal (-) terminal and the shield to Shield Ground terminal (Disregard shield for the IR sensors).

If Wiring a Series 4000 sensor, connect the clear wire (signal) to Signal (+) terminal, black wire (common) to Signal (-) terminal, shield wire to Shield Ground terminal, and red wire (power) to Power (4000 only) terminal.

If wiring to a sine wave output sensor consult factory.

6. For maximum EMI Protection, connect Model 310 ground lug to panel ground. **See Note #1**
7. Ensure that all connections are tight, then plug connector into header.

Note #1:

Included with every Model 310 is a 310IK kit containing a screw, lock washer and ground lead to connect the Model 310 to Earth Ground. This will help prevent electrical interference from affecting the Model 310's normal operation.

Figure 3: Model 310 Terminal Locations

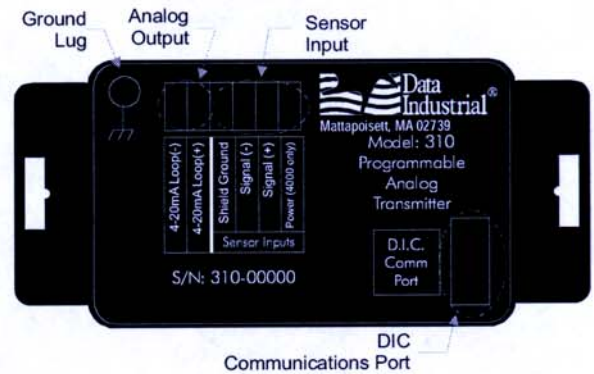

Side View - Typical 300 Series Removable Connector Wiring

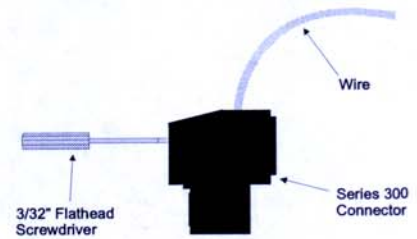
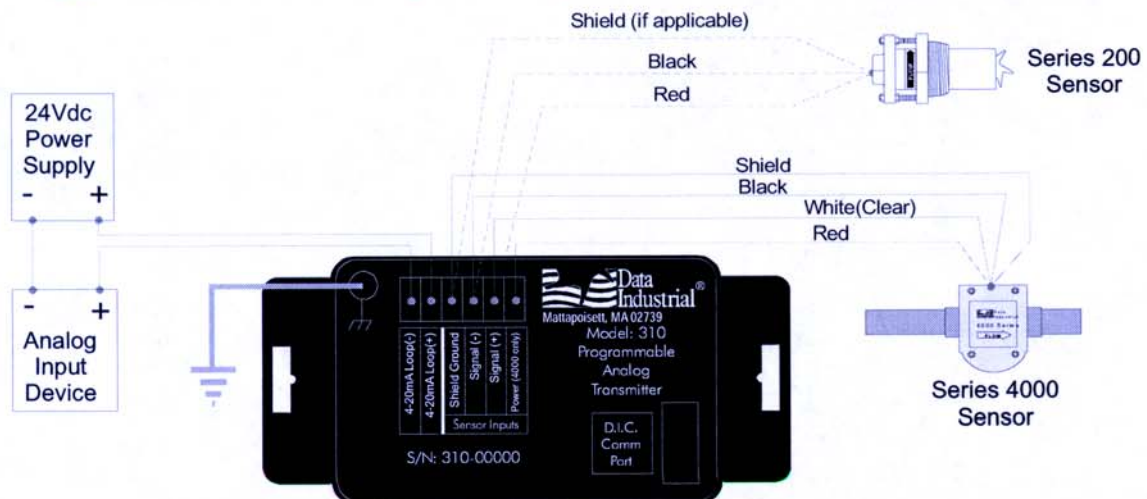

Figure 4: Model 310 Wiring to Analog Loop and Series 200 or Series 4000



Communications cable wiring

Field calibration requires a Data Industrial A310 Programming kit (consisting of a custom cable and software) and a PC running Windows® 9x, ME, NT, 2000 or XP. In order to program the Model 310 it must be connected to Loop-Power and the A301 cable must be connected between the Model 310 Comm port connector and an available DB9 COM port on a computer.

Location of the DIC Communication Port

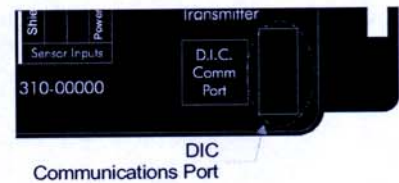

Note:

The Data Industrial A301 Cable will work with all 300 Series products. However the older version of the cable (A300) does not have sufficient bandwidth to work with the newer 340 Series Transmitters or SDI Flow Sensors.

Data Industrial provides free programming software updates via the Internet for all of 300 Series devices. Go to www.dataindustrial.com for these updates.

Programming Software Installation

Floppy Installation

Place the software installation Disk 1 into the floppy drive and run the setup.exe program to install.

CDROM Installation

Place the software CD into the CDROM drive and it should autostart. Click programming software, then click the Model 310 and the software installation will begin.

Web Installation

The Installation software can be found at the Data Industrial web site (www.dataindustrial.com) in the support section.

Model 310 Programming

Programming the Model 310 is accomplished by installing the Data Industrial programming software on a computer and entering data on templates of the Windows® based program.

1. Install the 310 PC Interface Software into the computer.
2. Connect the computer to the Model 310 transmitter using the Data Industrial A301 communications cable. Plug A301 cable to the socket labeled "D.I.C Comm Port" taking care to properly align the tab on the plug and socket to maintain polarity then plug the DB9 connector of the Data Industrial A301 communications cable to an available PC com port that has the Model 310 software installed.
3. Connect the Model 310 transmitter to a powered 4-20mA loop. (if setting up in the office a 9-24VDC power source can be used to simulate the loop).
4. Open the interface software and select the appropriate COM PORT as shown in the dialog box below.

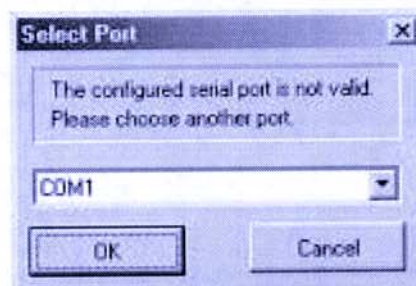

5. Open the Parameters Screen as shown below.

To go to calibration settings screen select "Parameters" from either place shown



6. Program using diagram below as a reference.

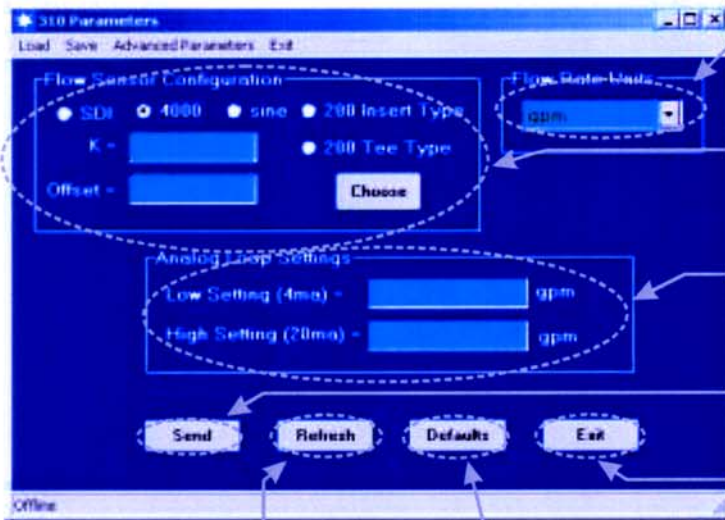

- Step #1**
Select Flow Rate Units.
- Step #2**
Select Sensor Type and Enter K and offset numbers.
See Note #1
- Step #3**
Enter 4mA Rate and 20mA Rate.
- Step #4**
Press **Send** to transmit calibration data to the 310.
- Step #5**
Press to exit Parameters screen and go back to the main screen.

Press to refresh the parameters screen with the current 310 settings.

Press to restore the factory defaults
To save the factory defaults Send must be pressed before values take effect.

Note #1

Sdi - If the SDI sensor type is selected the required K and offset values can be found the the SDI owners manual.

4000 - If the 4000 sensor type is selected, click the choose button and select the sensor from the pull down box that appears.

Sine - Provided for connection to sensors which have a sine wave output. Please consult sensor manufacturer for the calibration settings.

200 Insert Type - If the 200 Insert Sensor type is selected the required K and offset can be found the the 200 owners manual or if the manual is not handy the calculate button can be pushed and an inside pipe diameter can be entered and once calculate is pressed a K and offset will automatically be entered in.

200 Tee Type - If the 200 tee type is selected, click the choose button and select the sensor from the pull down box that appears.

Model 310 Specifications

Power Requirements:

Loop Input Voltage 9-35VDC

Input Frequency:

0.4 to 10 KHz

Load Resistance

Max 750Ω@24VDC

Output Response Time

Varies with filter

Temperature (operating):

-29°C to 70°C

-20°F to 158°F

Temperature (storage):

-40°C to 85°C

-40°F to 185°F

Accuracy

± 0.04% of reading over entire span

Linearity

0.1% of full scale

Warranty

Data Industrial Corporation ("Seller") of 11 Industrial Drive, Mattapoisett, Massachusetts 02739-0740, U.S.A., warrants to the original purchaser of its product that such product manufactured by Data Industrial Corporation shall be free from defects in materials or workmanship when installed, serviced and operated according to Data Industrial Corporation instructions or in other such normal use. This warranty is effective for a period of 12 months from the date of installation by the Purchaser or 18 months from the date of shipment by the "Seller" whichever occurs or terminates first. This limited warranty does not cover damage or loss resulting from corrosion or erosion caused by acids or other chemicals or by severe environmental conditions or negligent or improper installation or improper operation, misuse, accident, unauthorized repair or substitution of components other than those provided by the "Seller", and does not cover limited life components such as bearings, shafts, impellers where wear rate is a function of application and environment. Any component not manufactured by the "Seller" but included in its products shall not be covered by this warranty and is sold only under such warranty as the manufacturer may provide.

If Buyer or Purchaser wishes to make a claim hereunder, he shall send written notice of any defect within the warranty period, to "Seller" at the above address. "Seller" may at its sole option instruct Buyer to ship subject part, postage prepaid, to the "Seller" at above address or authorize a representative to inspect the part on site. "Seller" will at its sole option repair or replace any defective product covered by this warranty. If Buyer makes repairs or alterations to any product or part covered by this warranty without "Sellers" prior written approval, this warranty shall be null and void.

The foregoing shall constitute Buyers or Purchasers sole and exclusive remedy against "Seller", and no other remedy, including but not limited to, incidental or consequential damages for personal injury, loss of fluids, gases or other substances or for loss of profits or injury to property or person shall be available to the Buyer or Purchaser. The warranty extended herein shall be in lieu of any other implied warranty of merchantability or fitness for a particular purpose, and seller shall bear no liability for representatives or retail sellers. In no event shall Data Industrial Corporation be liable for any contingent, incidental, or consequential damage or expenses due to partial or complete inoperability of its product.

All rights reserved. No part of this work covered by the copyrights hereon may be reproduced or copied in any form or by any means - graphic, electronic, or mechanical, including photocopying, recording, taping, or information and retrieval systems -- without written permission of Data Industrial.

Copyright © 2003

Data Industrial Corporation

11 Industrial Drive

Mattapoisett, MA 02739

TEL: 508-758-6390

FAX: 508-758-4057

email: sales@dataindustrial.com

service@dataindustrial.com

web site: www.dataindustrial.com



Specifications subject to change without notice.

Ordering Information			
Nominal Pipe Size		Model	Part Number
2"	DN50	VSR-2	1144402
2 1/2"	DN65	VSR-2 1/2	1144425
3"	DN80	VSR-3	1144403
3 1/2"	-	VSR-3 1/2	1144435
4"	DN100	VSR-4	1144404
5"	-	VSR-5	1144405
6"	DN150	VSR-6	1144406
8"	DN200	VSR-8	1144408

Optional: Cover Tamper Switch Kit, stock no. 0090148

Replaceable Components: Retard/Switch Assembly, stock no. 1029030

UL, CUL and CSFM Listed, FM Approved, LPCB Approved, For CE Marked (EN12259-5) / VdS Approved model use VSR-EU

Service Pressure: 450 PSI (31 BAR) - UL

Flow Sensitivity Range for Signal:

4-10 GPM (15-38 LPM) - UL

Maximum Surge: 18 FPS (5.5 m/s)

Contact Ratings: Two sets of SPDT (Form C)

10.0 Amps at 125/250VAC

2.0 Amps at 30VDC Resistive

10 mAmps min. at 24VDC

Conduit Entrances: Two knockouts provided for 1/2" conduit.

Individual switch compartments suitable for dissimilar voltages.

Environmental Specifications:

- NEMA 4/IP54 Rated Enclosure suitable for indoor or outdoor use with factory installed gasket and die-cast housing when used with appropriate conduit fitting.
- Temperature Range: 40°F - 120°F, (4.5°C - 49°C) - UL
- Non-corrosive sleeve factory installed in saddle.

Service Use:

Automatic Sprinkler

NFPA-13

One or two family dwelling

NFPA-13D

Residential occupancy up to four stories

NFPA-13R

National Fire Alarm Code

NFPA-72

⚠ WARNING

- Installation must be performed by qualified personnel and in accordance with all national and local codes and ordinances.
- Shock hazard. Disconnect power source before servicing. Serious injury or death could result.
- Risk of explosion. Not for use in hazardous locations. Serious injury or death could result.

CAUTION

Waterflow switches that are monitoring wet pipe sprinkler systems shall not be used as the sole initiating device to discharge AFFF, deluge, or chemical suppression systems. Waterflow switches used for this application may result in unintended discharges caused by surges, trapped air, or short retard times.

General Information

The Model VSR is a vane type waterflow switch for use on wet sprinkler systems. It is UL Listed and FM Approved for use on steel pipe; schedules 10 through 40, sizes 2" thru 8" (50 mm thru 200 mm). LPC approved sizes are 2" thru 8" (50 mm thru 200 mm). See Ordering Information chart.

The VSR may also be used as a sectional waterflow detector on large systems. The VSR contains two single pole, double throw, snap action switches and an adjustable, instantly recycling pneumatic retard. The switches are actuated when a flow of 10 GPM (38 LPM) or more occurs downstream of the device. The flow condition must exist for a period of time necessary to overcome the selected retard period.

Enclosure

The VSR switches and retard device are enclosed in a general purpose, die-cast housing. The cover is held in place with two tamper resistant screws which require a special key for removal. A field installable cover tamper switch is available as an option which may be used to indicate unauthorized removal of the cover. See bulletin number 5401103 for installation instructions of this switch.

Installation (see Fig. 1)

These devices may be mounted on horizontal or vertical pipe. On horizontal pipe they shall be installed on the top side of the pipe where they will be accessible. The device should not be installed within 6" (15 cm) of a fitting which changes the direction of the waterflow or within 24" (60 cm) of a valve or drain.

NOTE: Do not leave cover off for an extended period of time.

Drain the system and drill a hole in the pipe using a hole saw in a slow speed drill (see Fig. 1). Clean the inside pipe of all growth or other material for a distance equal to the pipe diameter on either side of the hole. Roll the vane so that it may be inserted into the hole; do not bend or crease it. Insert the vane so that the arrow on the saddle points in the direction of the waterflow. Take care not to damage the non-corrosive bushing in the saddle. The bushing should fit inside the hole in the pipe. Install the saddle strap and tighten nuts alternately to required torque (see the chart in Fig. 1). The vane must not rub the inside of the pipe or bind in any way.

CAUTION

Do not trim the paddle. Failure to follow these instructions may prevent the device from operating and will void the warranty.

Fig. 1

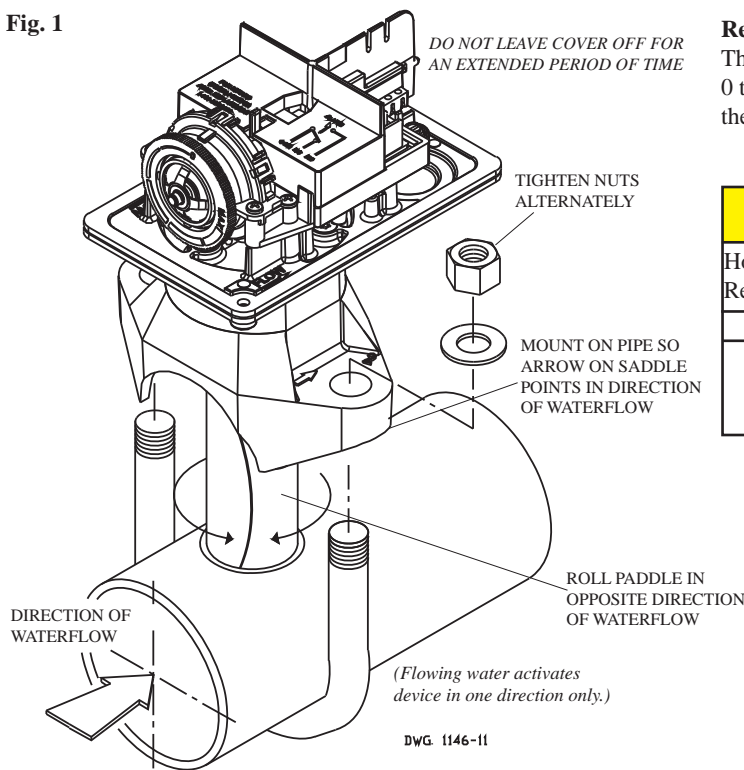

Retard Adjustment

The delay can be adjusted by rotating the retard adjustment knob from 0 to the max setting (60-90 seconds). The time delay should be set at the minimum required to prevent false alarms

CAUTION

Hole must be drilled perpendicular to the pipe and vertically centered. Refer to the Compatible Pipe/Installation Requirements chart for size.

Correct	Incorrect

ADAPTER 50mm ADAPTER

20mm ±2mm MAX.

DN50 ONLY

USE (2) 5180162 ADAPTERS AS SHOWN ABOVE

DWG# 1146-1F

Compatible Pipe/ Installation Requirements																
Model	Nominal Pipe Size		Nominal Pipe O.D.		Pipe Wall Thickness								Hole Size		U-Bolt Nuts Torque	
	inch	mm	inch	mm	Schedule 10 (UL)		Schedule 40 (UL)		BS-1387 (LPC)		DN (VDS)		inch	mm	ft-lb	n-m
VSR-2	2	DN50	2.375	60.3	0.109	2.77	0.154	3.91	0.142	3.6	0.091	2.3	1.25 + .125/-0.062	33.0 ± 2.0	20	27
VSR-2 1/2	2.5	-	2.875	73.0	0.120	3.05	0.203	5.16	-	-	-	-				
VSR-2 1/2	-	DN65	3.000	76.1	-	-	-	-	0.142	3.6	0.102	2.6				
VSR-3	3	DN80	3.500	88.9	0.120	3.05	0.216	5.49	0.157	4.0	0.114	2.9	2.00 ± .125	50.8 ± 2.0		
VSR-3 1/2	3.5	-	4.000	101.6	0.120	3.05	0.226	5.74	-	-	-	-				
VSR-4	4	DN100	4.500	114.3	0.120	3.05	0.237	6.02	0.177	4.5	0.126	3.2				
VSR-5	5	-	5.563	141.3	0.134	3.40	0.258	6.55	-	-	-	-				
VSR-6	6	DN150	6.625	168.3	0.134	3.40	0.280	7.11	0.197	5.0	0.157	4.0				
VSR-8	8	DN200	8.625	219.1	0.148	3.76	0.322	8.18	0.248	6.3	0.177	4.5				

NOTE: For copper or plastic pipe use Model VSR-CF.

Fig. 2
To remove knockouts: Place screwdriver at inside edge of knockouts, not in the center.

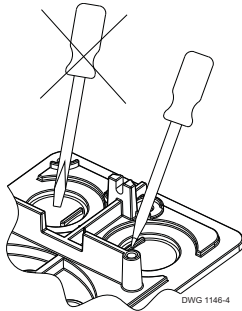

DWG. 1146-4

NOTICE

Do not drill into the base as this creates metal shavings which can create electrical hazards and damage the device. Drilling voids the warranty.

Fig. 3
Break out thin section of cover when wiring both switches from one conduit entrance.

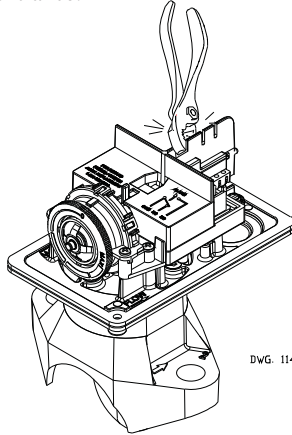

DWG. 1146-13

Fig. 4 Switch Terminal Connections Clamping Plate Terminal

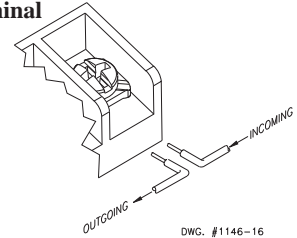

DWG. #1146-16

WARNING

An uninsulated section of a single conductor should not be looped around the terminal and serve as two separate connections. The wire must be severed, thereby providing supervision of the connection in the event that the wire become dislodged from under the terminal. Failure to sever the wire may render the device inoperable risking severe property damage and loss of life.

Do not strip wire beyond 3/8" of length or expose an uninsulated conductor beyond the edge of the terminal block. When using stranded wire, capture all strands under the clamping plate.

Fig. 5 Typical Electrical Connections

Notes:

1. The Model VSR has two switches, one can be used to operate a central station, proprietary or remote signaling unit, while the other contact is used to operate a local audible or visual annunciator.
2. A condition of LPC Approval of this product is that the electrical entry must be sealed to exclude moisture.
3. For supervised circuits, see "Switch Terminal Connections" drawing and warning note (Fig. 4).

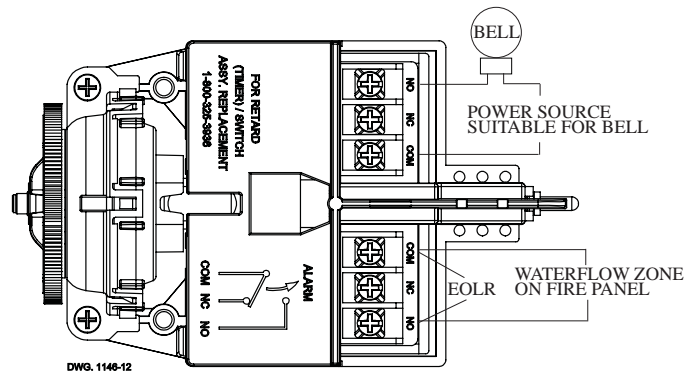

DWG. 1146-12

Testing

The frequency of inspection and testing for the Model VSR and its associated protective monitoring system shall be in accordance with applicable NFPA Codes and Standards and/or the authority having jurisdiction (manufacturer recommends quarterly or more frequently).

If provided, the inspector's test valve shall always be used for test purposes. If there are no provisions for testing the operation of the flow detection device on the system, application of the VSR is not recommended or advisable.

A minimum flow of 10 GPM (38 LPM) is required to activate this device.

NOTICE

Advise the person responsible for testing of the fire protection system that this system must be tested in accordance with the testing instructions.

Fig. 7 Mounting Dimensions

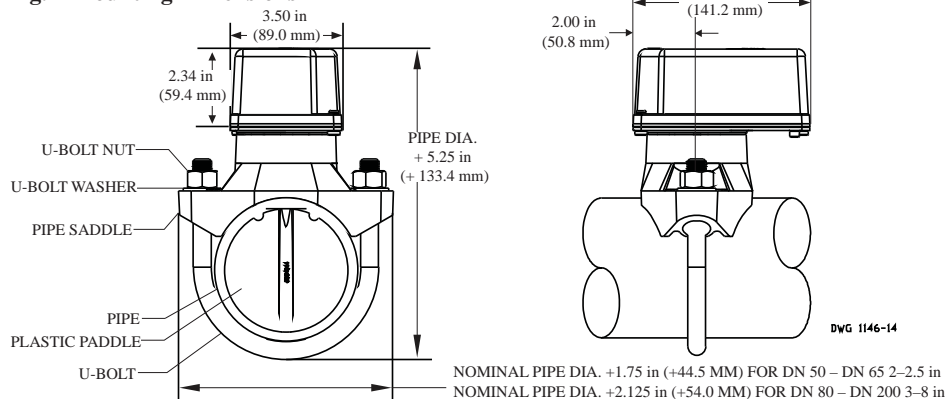

DWG. 1146-14

Fig. 8

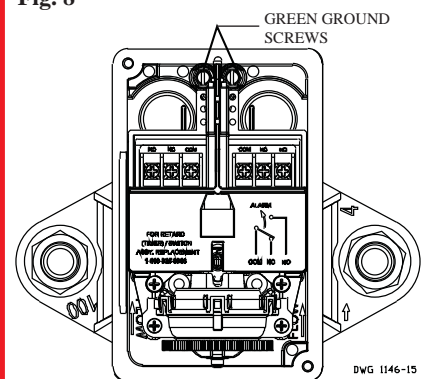

DWG. 1146-15

Maintenance

Inspect detectors monthly. If leaks are found, replace the detector. The VSR waterflow switch should provide years of trouble-free service. The retard and switch assembly are easily field replaceable. In the unlikely event that either component does not perform properly, please order replacement retard switch assembly stock #1029030 (see Fig. 6). There is no maintenance required, only periodic testing and inspection.

Retard/Switch Assembly Replacement (See Fig. 6)

NOTICE

The Retard/Switch Assembly is field-replaceable without draining the system or removing the waterflow switch from the pipe

1. Make sure the fire alarm zone or circuit connected to the waterflow switch is bypassed or otherwise taken out of service.
2. Disconnect the power source for local bell (if applicable).
3. Identify and remove all wires from the waterflow switch.
4. Remove the (2) mounting screws holding retard/switch assembly to the base. **Do not** remove the (2) retard housing screws.
5. Remove the retard assembly by lifting it straight up over the tripstem.
6. Install the new retard assembly. Make sure the locating pins on the retard/switch assembly fit into the locating pin bosses on the base.
7. Re-install the (2) original mounting screws.
8. Reconnect all wires. Perform a flow test and place the system back in service.

Fig. 6

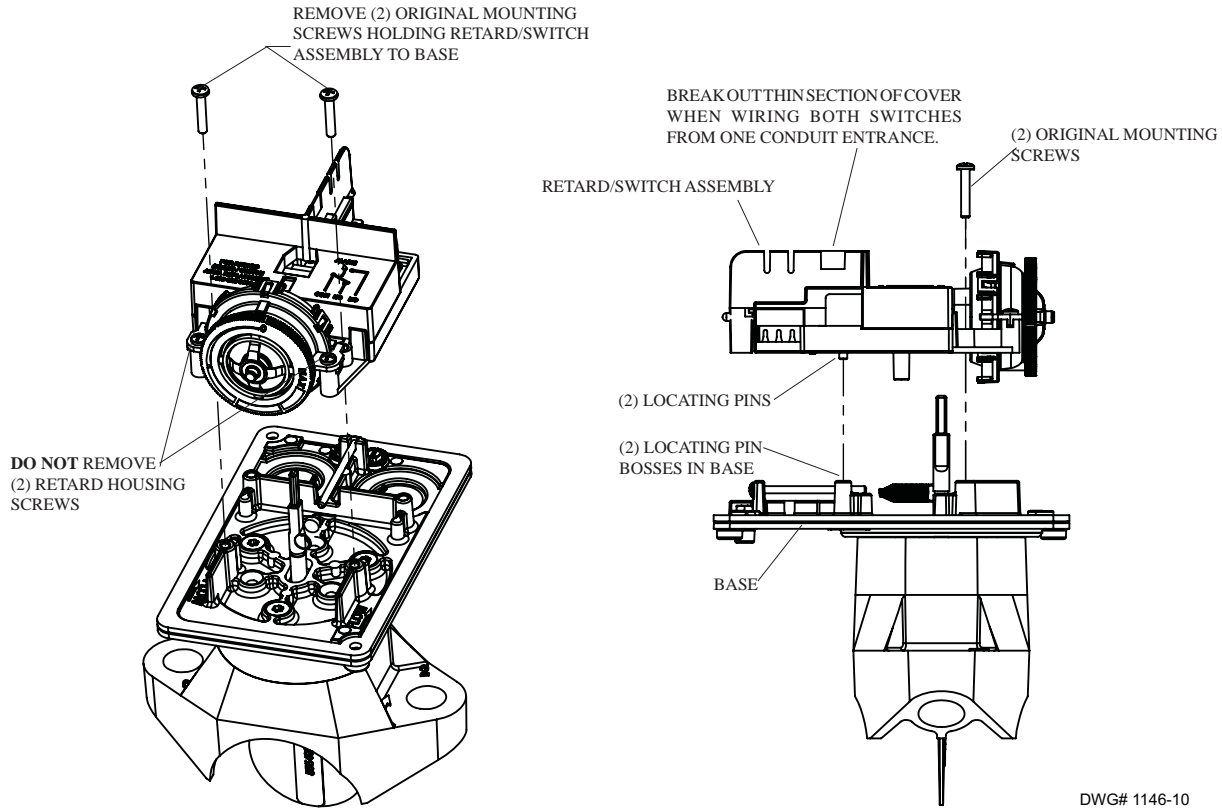

Removal of Waterflow Switch

- To prevent accidental water damage, all control valves should be shut tight and the system completely drained before waterflow detectors are removed or replaced.
- Turn off electrical power to the detector, then disconnect wiring.
- Loosen nuts and remove U-bolts.
- Gently lift the saddle far enough to get your fingers under it. With your fingers, roll the vane so it will fit through the hole while continuing to lift the waterflow detector saddle.
- Lift detector clear of pipe.

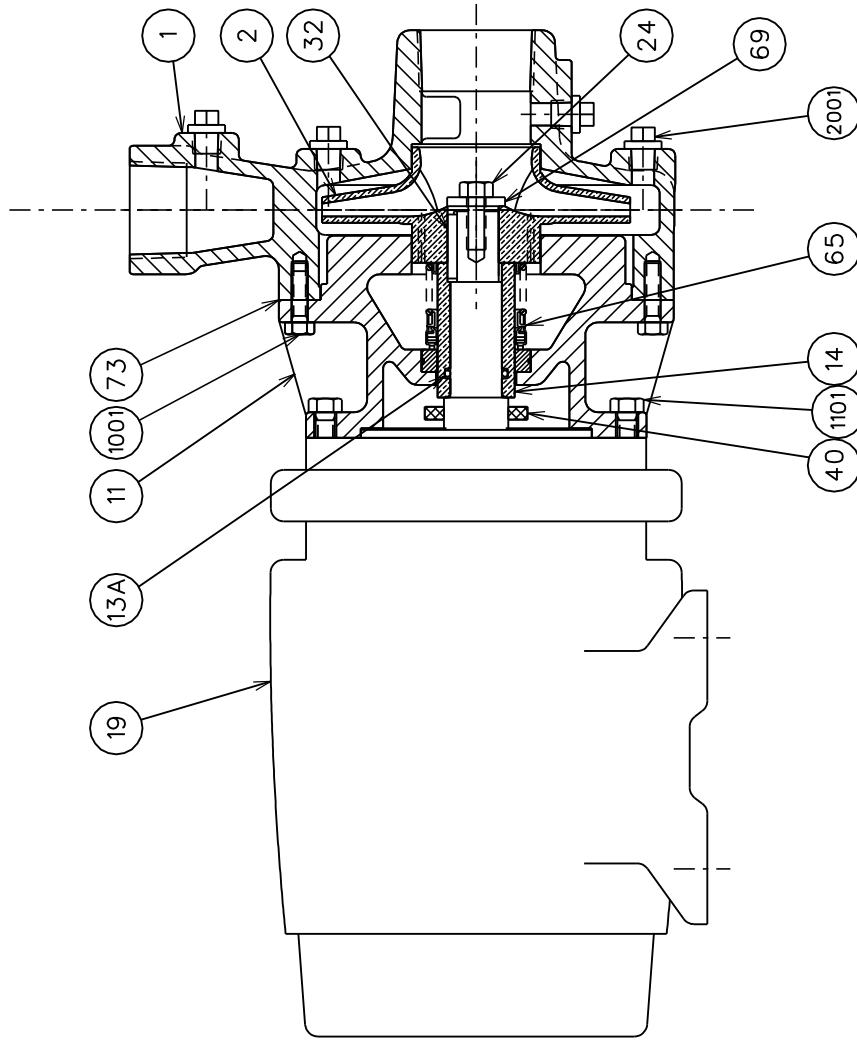

NOTE: SOME FEATURES SHOWN ROTATED FOR CLARITY

ITEM	DESCRIPTION
1	CASING
2	IMPELLER
11	VOLUTE COVER
13A	SHAFT SLEEVE O-RING
14	SHAFT SLEEVE
19	MOTOR
24	IMPELLER SCREW
32	IMPELLER KEY
40	DEFLECTOR
65	MECHANICAL SEAL
69	IMPELLER WASHER
73	GASKET
1001	CASING BOLT
1101	VOLUTE COVER BOLT
2001	PIPE PLUG

Dwg. No.	B05-83429	
	DATE	3-12-02
DRAWN	SPENCER	APPRVD.
SCALE	NONE	EJC

ASSEMBLY SECTION
FOR
2 X 1/2 X 6 HES PUMP

PATTERSON PUMP COMPANY
A SUBSIDIARY OF THE GORMAN-RUPP COMPANY

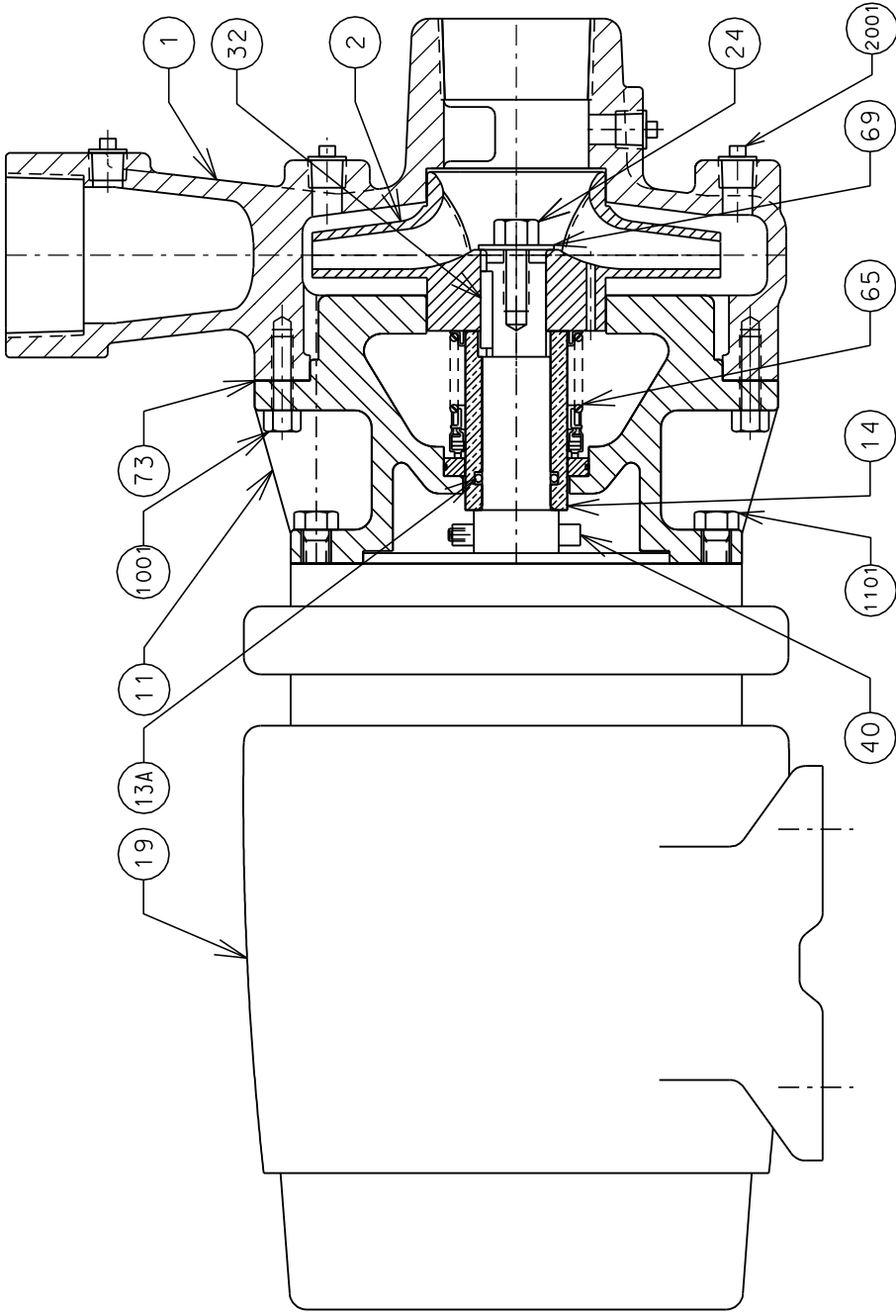

NOTE: SOME FEATURES SHOWN ROTATED FOR CLARITY

ITEM	DESCRIPTION
1	CASING
2	IMPELLER
11	VOLUTE COVER
13A	SHAFT SLEEVE O-RING
14	SHAFT SLEEVE
19	MOTOR
24	IMPELLER SCREW
32	IMPELLER KEY
40	DEFLECTOR
65	MECHANICAL SEAL
69	IMPELLER WASHER
73	GASKET
1001	CASING BOLT
1101	VOLUTE COVER BOLT
2001	PIPE PLUG

DWG. NO.	B05-82811		REV.
	DRAWN	DATE	
SCALE	L HOWARD	2-8-02	
	NONE	APPRVD.	EJC

ASSEMBLY SECTION
for
2X2X6 HES

PATTERSON PUMP COMPANY
A SUBSIDIARY OF THE GORMAN-RUPP COMPANY

2 x 2 x 8 HES END SUCTION PUMP

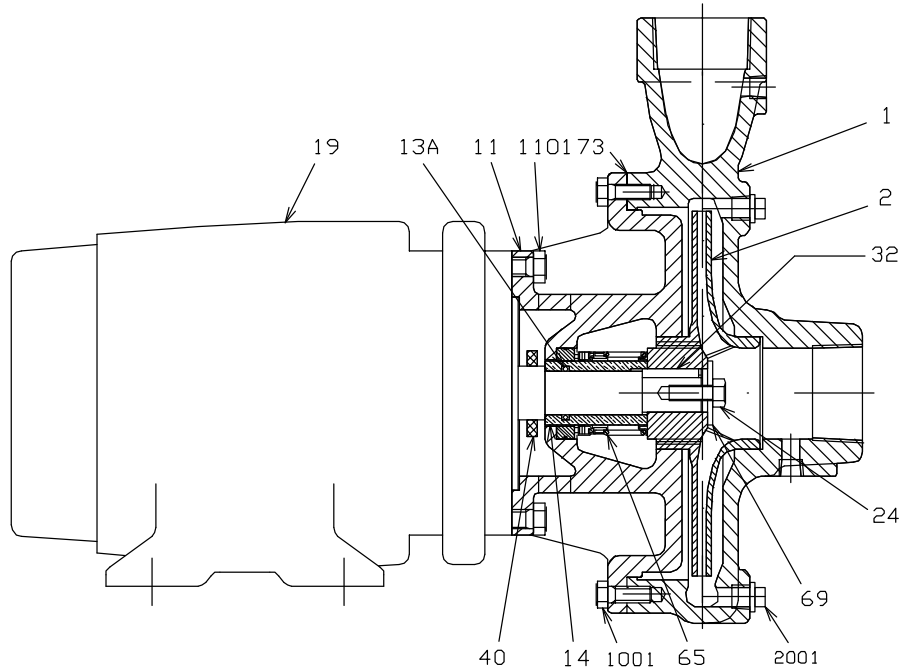

FEATURES:

- ⊙ REGISTERED FITS AT THE VOLUTE COVER AND VOLUTE MAINTAIN PUMP ALIGNMENT
- ⊙ DYNAMICALLY BALANCED IMPELLER
- ⊙ HYDROSTATICALLY TESTED TO 1 1/2 TIMES SHUT-OFF
- ⊙ FITTED WITH SHAFT SLEEVE AND SELF FLUSHING MECHANICAL SEAL
- ⊙ O-RING SEAL UNDER SHAFT SLEEVE
- ⊙ BACK PULL-OUT DESIGN ALLOWS REMOVAL OF ROTATING ELEMENT WITHOUT DISTURBING SUCTION AND DISCHARGE CONNECTIONS

ITEM	DESCRIPTION	MATERIAL
1	CASING	Cast Iron - ASTM A48-CL40
2	IMPELLER	Bronze - B584-875
11	VOLUTE COVER	Cast Iron - ASTM A48-CL35
13A	SHAFT SLEEVE O-RING	Nitrile
14	SHAFT SLEEVE	Bronze - B505-954
19	MOTOR	Manufacturers Standard
24	IMPELLER SCREW	Stainless Steel - ASTM F593 GR 1 Type 304
32	IMPELLER KEY	Stainless Steel - ASTM Type 304
40	DEFLECTOR	Neoprene
65	MECHANICAL SEAL	Carbon vs. Silicon Carbide
69	IMPELLER WASHER	Stainless Steel - AISI 416
73	GASKET	Vellumold
1001	CASING BOLT	Steel - SAE J429 GR 2
1101	VOLUTE COVER BOLT	Steel - SAE J429 GR 2
2001	PIPE PLUG	Cast Iron

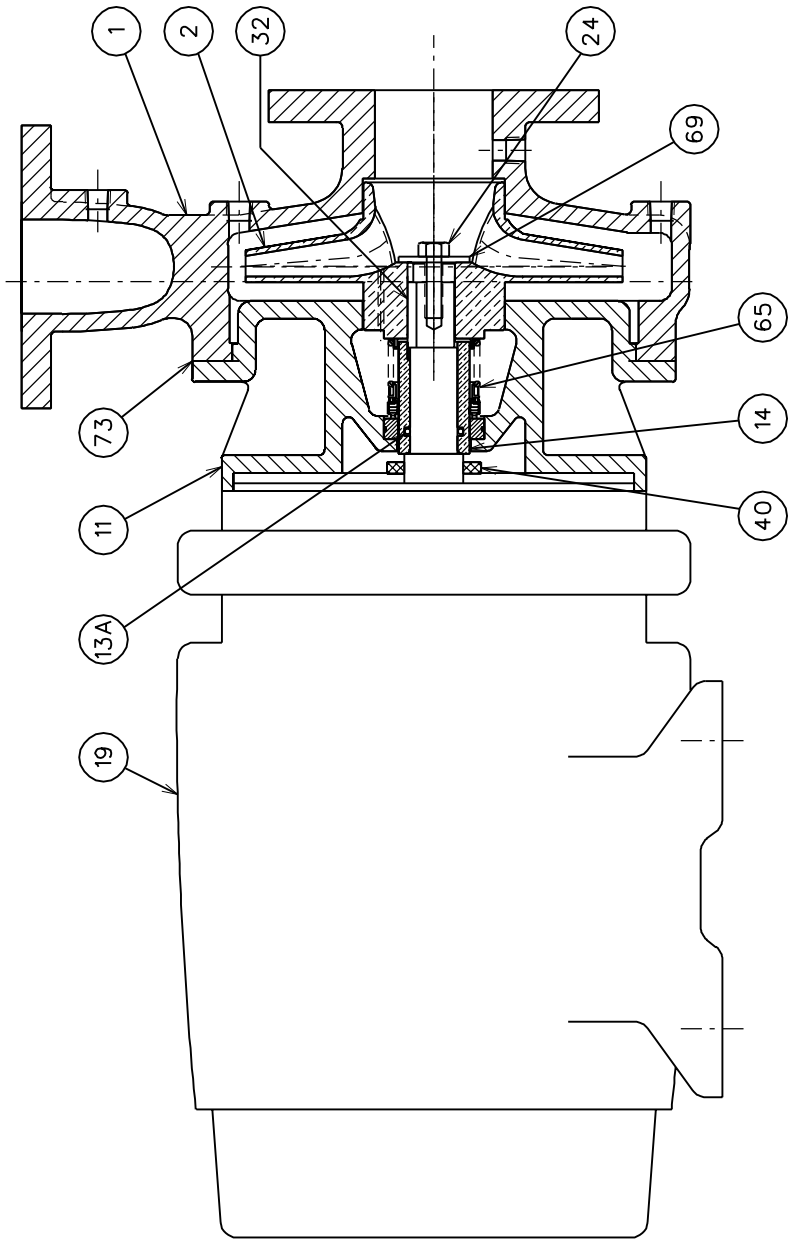

NOTE: SOME FEATURES SHOWN ROTATED FOR CLARITY

ITEM	DESCRIPTION
1	CASING
2	IMPELLER
11	VOLUTE COVER
13A	SHAFT SLEEVE O-RING
14	SHAFT SLEEVE
19	MOTOR
24	IMPELLER SCREW
32	IMPELLER KEY
40	DEFLECTOR
65	MECHANICAL SEAL
69	IMPELLER WASHER
73	GASKET

DWG. NO.	B05-83431	
	REV.	
DRAWN	SPENCER	DATE
SCALE	NONE	APPRVD.
		3-12-02
		EJC

ASSEMBLY SECTION
FOR
2 1/2 X 2 X 8 HES PUMP

PATTERSON PUMP COMPANY
A SUBSIDIARY OF THE CORMAN-RUPP COMPANY

MATERIAL LIST HES PUMPS

Reference: Assembly Section

NUMBER	DESCRIPTION	MATERIAL
1	Casing	Cast Iron – ASTM A48-CL40
2	Impeller	Bronze – ASTM B584-875
11	Volute Cover	Cast Iron – ASTM A48-CL40
13A	Shaft Sleeve O-ring	Nitrile
14	Shaft Sleeve	Bronze – ASTM B505-954
19	Motor	Mfg. Std.
24	Impeller Screw	Stainless Steel – Type 304
32	Impeller Key	Stainless – Type 304
40	Deflector (V-ring)	Nitrile
65	Mechanical Seal	Carbon vs Silicone Carbide
69	Impeller Washer	Stainless – Type 416 SS
73	Gasket	Velumoid
1001	Casing Bolts	GR 2 –Carbon Steel
1101	Volute Cover Bolts	Gr 2 – Carbon Steel
2001	Pipe Plug	Steel – Mfg. Std.